

INSTALLATION AND MAINTENANCE MANUAL FOR
EXPLOSIONPROOF LIGHT FITTING

EXL450LED-...-A3



Carefully read the instructions before
mounting the light fitting.

TABLE OF CONTENTS

1.	GENERAL INFORMATION.....	3
2.	TECHNICAL INFORMATION	5
3.	PHOTOMETRICAL DATA.....	7
4.	CONSTRUCTION DESCRIPTION	7
5.	PRELIMINAIRES	7
6.	LIGHT FITTING MOUNTING	8
7.	ELECTRICAL CONNECTION	10
8.	EMERGENCY WORKING	11
9.	CONDITIONS OF SAFETY USE.....	12
10.	CLEANING	13
11.	REPAIRING AND EXCHANGE PARTS.....	13
12.	LIGHT SOURCE EXCHANGE	13
13.	TRANSPORT AND CONDITIONS OF STORAGE.....	13
14.	DISPOSAL OF WASTE EQUIPMENT.....	13
15.	WARRANTY	14

1. GENERAL INFORMATION

EXL450LED light fittings are designed to light indoor and outdoor areas in zone 2 of explosion hazard of gas, vapors or clouds of flammable liquids mixed with air which belongs to IIA, IIB or IIC explosion group, T1-T6 temperature class (take a look at label on the next page). EXL450LED light fittings are also suitable to light areas in zones 21,22 of explosion hazard of dust and flammable fibers mixed with air which self-ignition temperature is higher than 105°C-180°C. Lamp is equipped with independent battery set.

EXL450LED-EX		- - 24 E - 50 -		- ALU -		- - -		- AMO90 -		- 3F -		- A3 -		- PRG -	
group		2	1	70	10	M	20	GL	NB	AMO90	3F			PRG	
explosionproof light fittings		3	2		20	P	25	PC	MB	AMO180				VENT	
type		4							WB	AMO360					
type 450									OB						
light source									ASY						
LED modules															
LED module type															
LED module quantity															
driving current															
power supply															
24E - 220-240V, 50-60Hz															
wiring															
50 - single 5-pole terminal → 5 (1-phase)															
70 - single 7-pole terminal → 7 (3-phase)															
cable inlets - quantity															
10 - one cable inlet on the side of the housing → 1 0															
20 - two cable inlets on the side of the housing → 2 0															
cable inlets - material															
M - metal															
P - plastic															
cable inlets - size															
20 - Ø20															
25 - Ø25															
housing material															
ALU - anodized aluminum															
diffuser material															
GL - tempered glass															
PC - UV stabilised polycarbonate															
optics															
NB - narrow beam															
MB - medium beam															
WB - wide beam															
OB - oval beam															
ASY - asymmetric beam															
mountings															
check: <i>mountings</i>															
additional options															
3F - version adapted to work in a three-phase network, equipped with wiring 70 (L1, L2, L3, PE, N)															
emergency version															
A3 - additional emergency power module															
additional accessories															
PGR - version equipped with protection grid on the diffuser															
VENT - version equipped with explosionproof ventilated plugs (recommended in external use of the fitting)															

TECHNICAL INFORMATION

Ex marking:

- For EXL450LED - EX* - * - **E - ** - ***** - ALU - ** - ** - **** - ** - A3 - ***



II 3G Ex ec IIC T6...T4 Gc
II 2D Ex tb IIIC T80°C...T105°C Db

- EX marks of some versions.

Version	Temp class./ Max. surface temp.
EX2-1-...-A3	T6/T80 °C
EX2-2-...-A3	T5/T80 °C
EX3-1-...-A3	T5/T80 °C
EX3-2-...-A3	T4/T105 °C

Interpretation of the use restrictions of the device by means of the symbols in the above marking and on the label of the device:

Name	Symbol	Description
Special explosionproof protection marking		Symbol of device intended for use in potentially explosive atmospheres.
Device group	II	Device intended for use in explosive atmospheres other than underground mine.
Device category	3G	Device can safely operate in zone 2 of the explosion hazard of gases, vapors, and mists of flammable liquids with air.
	2D	Device can safely operate in zones 21 or 22 dust explosion hazard.
Type of execution	Ex ec	Device secured with increased safety construction type "e".
	Ex tb	Device secured from dust ignition with the housing type „t”.
Group	IIC	Device can be used in the presence of explosion hazard gases, vapors, and mists of flammable liquids with air classified as explosive groups IIA, IIB, IIC.
	IIIC	Device can be used in the presence of explosion hazard of combustible dusts and filaments belonging to explosion groups IIIA, IIIB, IIIC (all types of dusts).
Temperature class	T4	Device intended for use in potentially explosive atmospheres of gases with self-ignition temperature > 135 °C
	T5	Device intended for use in potentially explosive atmospheres of gases with self-ignition temperature > 100 °C
	T6	Device intended for use in potentially explosive atmospheres of gases with self-ignition temperature > 185 °C
Temperature	T80°C	The glowing temperature of a given layer of dust or the self-ignition temperature of a dust cloud - with appropriate safety margins - must be higher than the maximum permissible temperature on the surface of the device, which in this case is 80°C
	T105°C	The glowing temperature of a given layer of dust or the self-ignition temperature of a dust cloud - with appropriate safety margins - must

		be higher than the maximum permissible temperature on the surface of the device, which in this case is 105°C.
Explosion protection level	Gc	Device intended for installation in zone 2 of gas explosion hazard, providing a „normal safety” and which will not become a source of ignition under normal conditions of use and during expected damage.
	Db	Device intended for installation in zones 21, 22 dust explosion hazard, providing a „high level of safety” and which will not become a source of ignition under normal conditions of use and during expected damage.

Protection degree: IP66/IP67
Admission wires diameter.: 1-2,5mm² (option: 6mm²)
Admission cable diameter: Ø 8-13mm (M/P20) / Ø 9-17mm (M/P25)
Voltage: **24E:** 220V-240V, 50-60Hz;
Protection class: I
Ambient temperature Ta:

Version	Working temperature (24E)	Working temperature (PC diffuser)
EX2-1	-20°C ... +45°C	-20°C ... +45°C
EX2-2	-20°C ... +45°C	-20°C ... +40°C
EX3-1	-20°C ... +45°C	-20°C ... +45°C
EX3-2	-20°C ... +45°C	-20°C ... +40°C

LED module risk group RG = 1

2. TECHNICAL INFORMATION

Type	Source power	Voltage	IP	Protection class	Power factor	Ambient temperature
EXL450LED-EX2-1*	103W	220V-240V, 50-60Hz;	66/67	I	≥0,98	Depends of version and module type
EXL450LED-EX2-2*	153W					
EXL450LED-EX3-1*	155W					
EXL450LED-EX3-2*	238W					

*The emergency version with A3 module consumes an additional 5 W of power.

VERSIONS

VERSION EX2 - A3 standard bracket AMO90

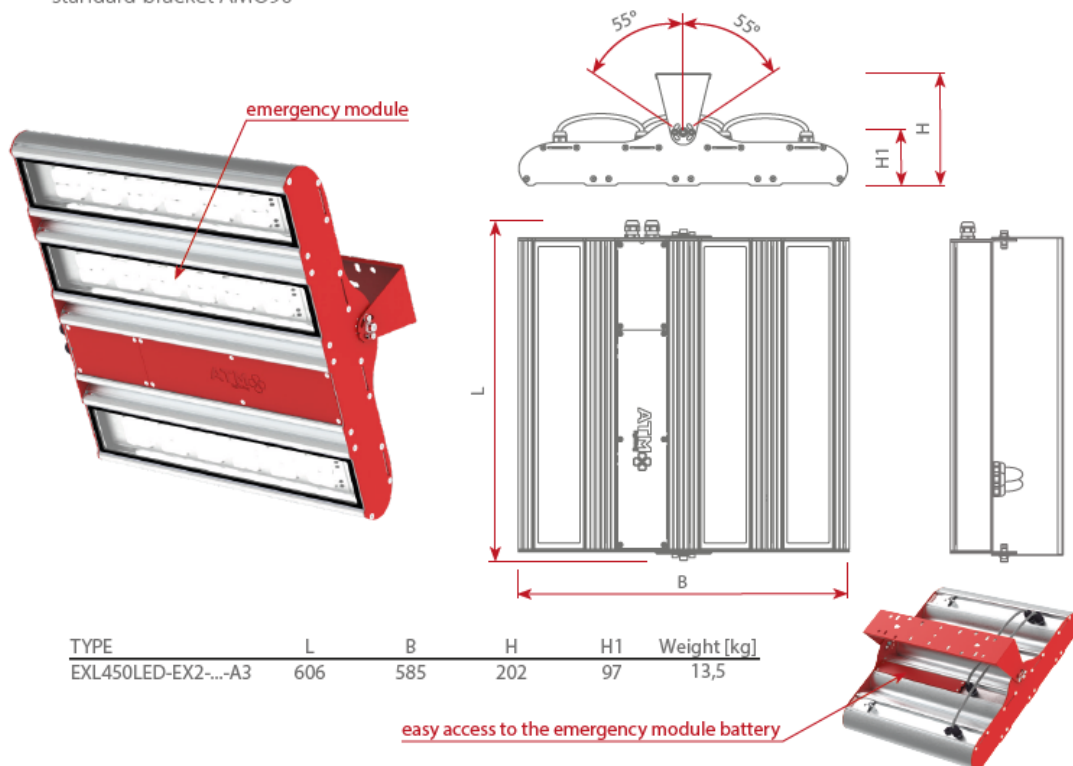

TYPE	L	B	H	H1	Weight [kg]
EXL450LED-EX2-...-A3	606	585	202	97	13,5

VERSION EX3 - A3 standard bracket AMO90

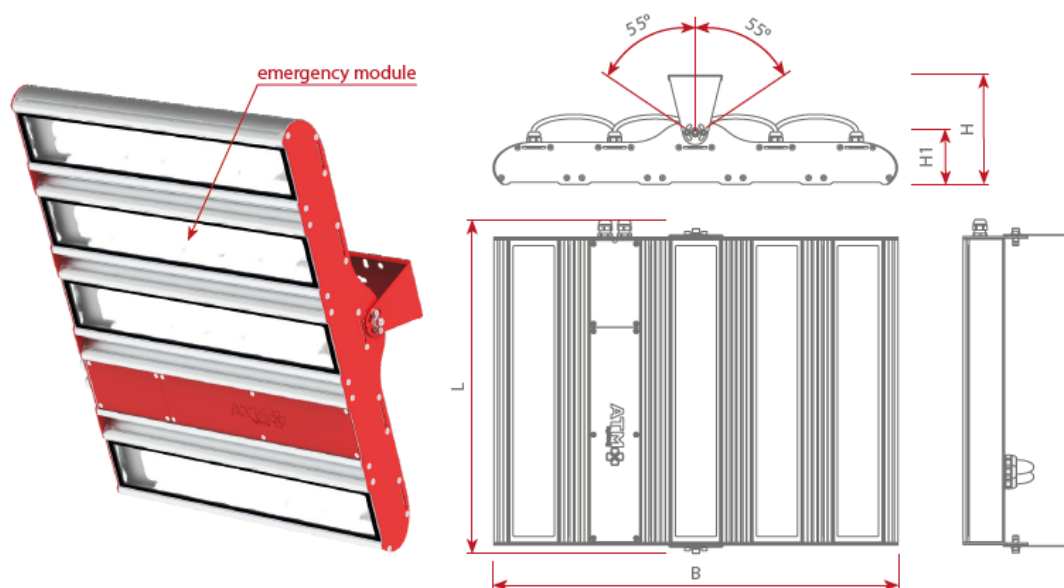

TYPE	L	B	H	H1	Weight [kg]
EXL450LED-EX3-...-A3	606	735	202	97	16,5

3. PHOTOMETRICAL DATA

Type	Average emergency luminous flux	Power of A3 module
EXL450LED-EX2-...-A3	900 lm	5 W
EXL450LED-EX3-...-A3		

Type	Average emergency luminous flux	Efficiency	Colour temperature	CRI	Lifetime
EXL450LED-EX2-1-...-A3	16000 lm	155 lm/W	4000K (Option: 6500K)	>70 (Option: >80)	>70000 h – „L70B10”
EXL450LED-EX2-2-...-A3	22000 lm	144 lm/W			>50000 h – „L80B10”
EXL450LED-EX3-1-...-A3	24000 lm	155 lm/W			
EXL450LED-EX3-2-...-A3	34000 lm	143 lm/W			

4. CONSTRUCTION DESCRIPTION

Light fittings are built according to common electrical engineering rules. The product meets the essential requirements of the Directives and the harmonized standards listed in the EU Declaration of Conformity. Used solutions and materials, electrical equipment and proper insulating spaces makes that during normal exploitation there is no possibility any sparks, electrostatic charge, dangerous heating or light fitting destruction caused by environment factors occurrence.

Light fittings are built as a one chamber equipment. Housing, endcaps and mounting tray are made of aluminum. Sealing is made of silicone.

Used terminals ensures safe and non-sparking connection of inner wires and admission cables. The diffuser is made of UV resistant polycarbonate (PC) or tempered glass.

Floodlights bodies should be equipped attested cable glands and plugs compliant with EX “e” or EX “d” certificate. Cable glands and plugs should provide protection class of IP66 or IP67 depending on floodlights version, in compliance with EN 60079-14 norm.

5. PRELIMINAIRES

SAFETY RULES

- Carefully read all the information included in the manual before mounting the light fitting.
- General safety rules must be followed.
- Failure to comply with rules of the installation and use can lead to personal injury or property loses. ATM Lighting sp. z o.o. company takes no responsibility in such cases.
- Failure to comply with rules included in manual results with void of the manufacturer warranty.
- Manufacturer takes no responsibility for any damages resulting from improper installation, maintenance or improper use.

- It is the responsibility of the user to perform the installation in accordance with this manual and the safety regulations and standards applicable to the type of installation
- In case of malfunction, the device must be turned off and returned for repair to the manufacturer or his authorized entity.



Before performing any installation work, including opening the enclosure, be absolutely sure to disconnect the unit from the power source

NECESSARY TOOLS

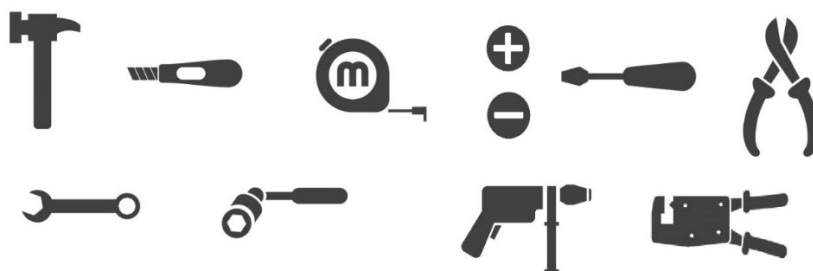

6. LIGHT FITTING MOUNTING

The EXL450LED is shipped with mounting brackets designed to be mounted to the ceiling wall or pipe.

Versions of mounting

AMO90
standard

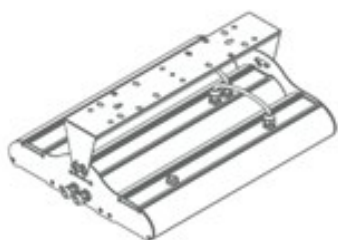
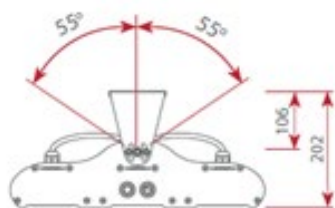

AMO360
optional

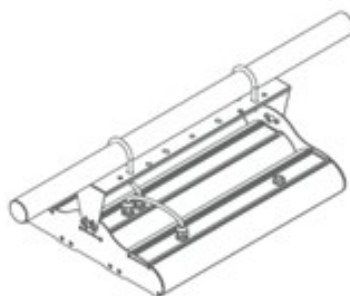

AMO180
optional

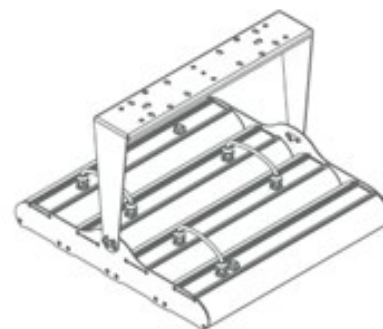
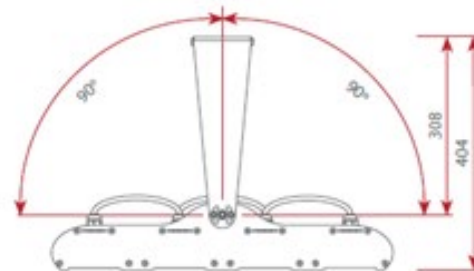

OPTIONAL EQUIPMENT

- Version equipped with protection net (PRG)

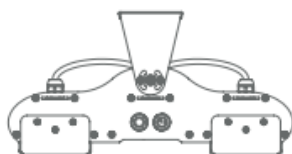
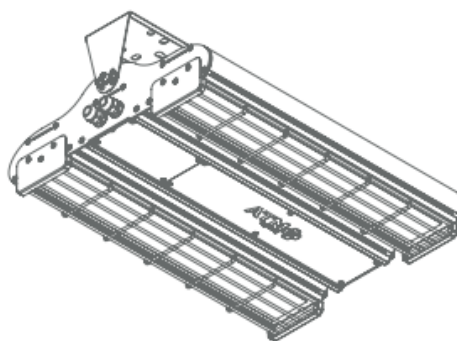
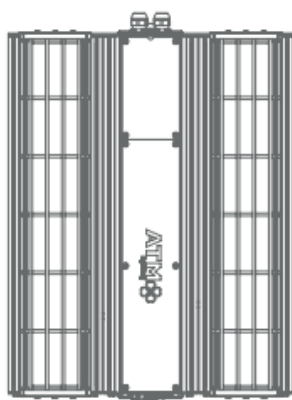

ADDITIONAL INFORMATION:

Light fitting equipped with additional grid which protects from the accidental damages.

- Version equipped with EX breathable caps (VENT)

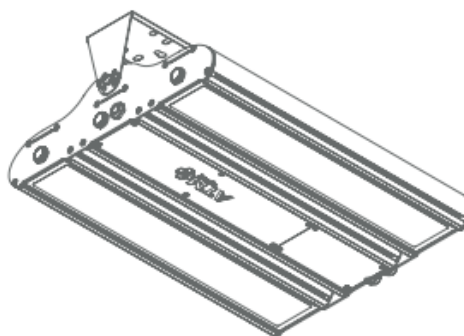
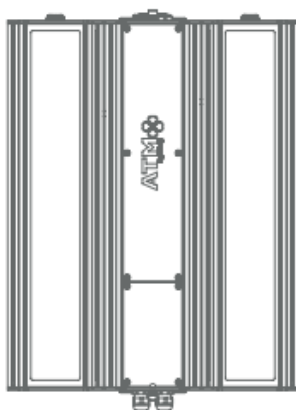

ADDITIONAL INFORMATION:

The light fitting is equipped with ventilated plugs (one for each chamber). The ventilated plug prevents from the condensation of water vapor inside the fitting. This version is recommended for external use of the fitting.

7. ELECTRICAL CONNECTION



Installation and electrical connection should be in accordance with the requirements of PN-EN 60079-14.

To connect power supply:

- enter the power cable to the housing through the cable entry (gland),
- carefully unisolate the wires (8-10mm), and put it into the connector according to a label inside the light fitting (L, PE, N, L'),
- precisely tighten power cable in the gland with two wrenches,
- check the effectiveness of grounding.
- Change the lock position at the battery connector from the disconnected OFF position to the connected ON position (according to the diagram below).

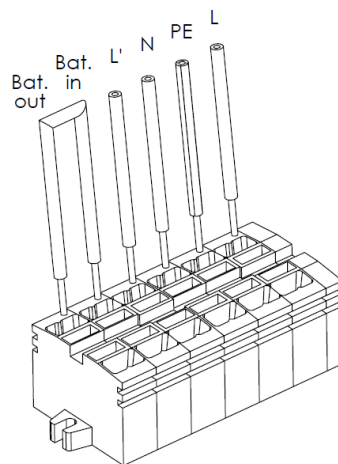

L'- switch line (when switched ON luminaire will turn ON/ when switched OFF luminaire will turn OFF)

Connection (wiring 50):

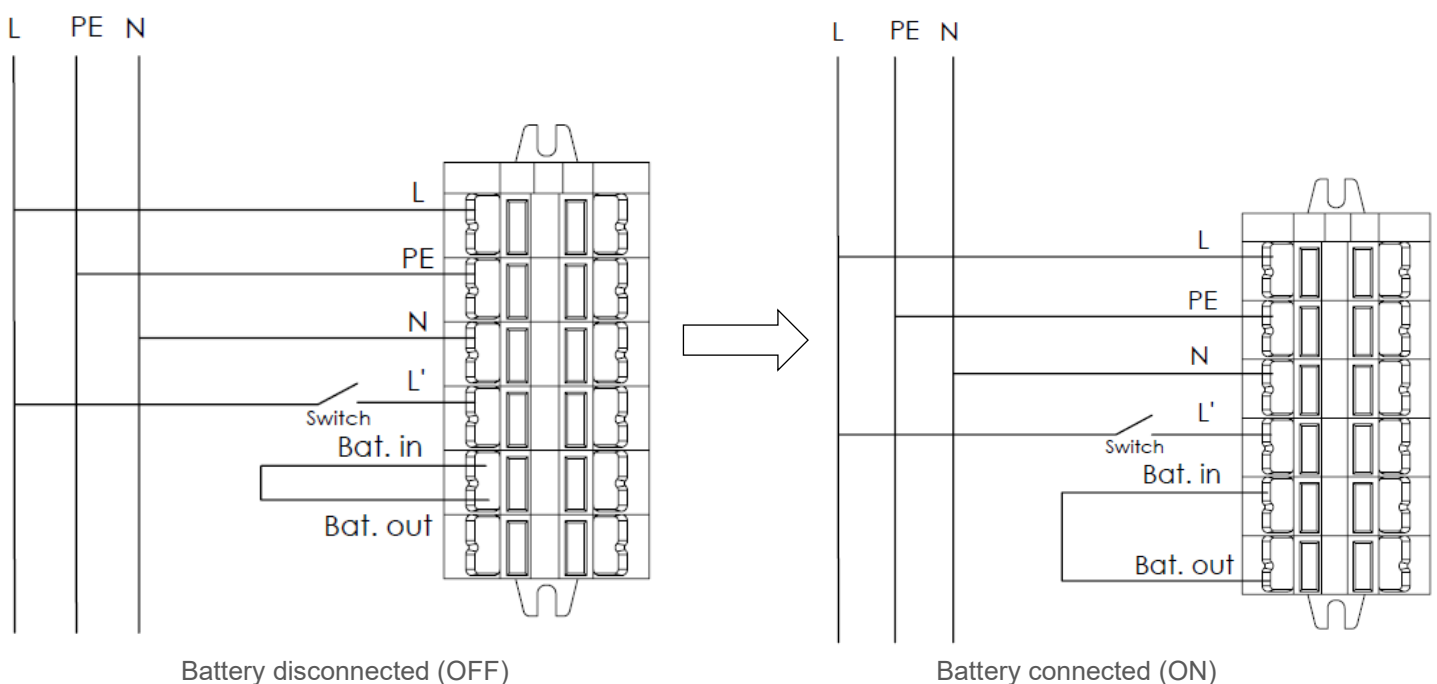



Remark:

- If neutral line is damaged or voltage occurs in it, a floodlight or group of floodlights may start to work under larger than predicted load, which in consequence may lead to damage of power delivery system.
- Use one wrench to tighten the sealing nut, while using the second wrench to block gland body against rotation, otherwise damage of the sealing can be caused and therefore sealing level will be decreased.
- Not following this remark may cause may damage the seals, resulting in lowering of IP rating and explosionproof security.

8. EMERGENCY WORKING



Remark:

- **Emergency module works only during the mains failure. During normal works it's stays off.**

The light fitting is equipped with emergency power supply module EM converterLED ST 205 made by TRIDONIC, which is powered by 230V AC, 50-60Hz. During normal work module charges the battery pack with appropriate current. Failure of mains supply will switch light fitting into emergency mode.

- Time of full charge of battery is 24h (first charge is 48h). Beside this emergency module has:
 - a) Stability control system – it ensures that battery is not overcharged or discharged too much, which may shorten its life or even destroy the battery.
 - b) Automatic switch system – switches light fitting between emergency and standard work.
 - c) Signaling system – LED which shows current work state.
- Battery should be connected to emergency module with mains supply switched off. After that mains must be switched on. During maintenance, transport or storage battery must be disconnected from emergency module. It is unacceptable to continuously switch on and off the mains when battery is connected to emergency module.
- To ensure reliable work of emergency module batteries must be changed each 4 years or when the capacity falls below 50% or emergency work time is lower than 3h. Temperature while battery charging must be $\geq 0^{\circ}\text{C}$
- Discharged battery obtains full capacity after 24h of charging. To ensure appropriate forming of battery first charging must last for 48h. It is unacceptable to make any test or switch light fitting into emergency mode during this time. After 48 hours light fitting must be switched into emergency mode to complete discharge of battery. Then the battery must be charged for 36h. This ends the process of forming.

LED indication	Status	Comment
Permanent green	System OK	AC mode
Fast flashing green (0,1 sec on – 0,1 sec off)		Function test underway
Slow flashing green (1 sec on – 1 sec off)		Duration test underway
Red LED on	Load failure	Open circuit / Short circuit / LED failure
Slow flashing red (1 sec on – 1 sec off)	Battery failure	Battery failed the duration test or function test / Battery is defect or deep discharged / incorrect battery voltage
Fast flashing red (0,1 sec on – 0,1 sec off)	Charging failure	Incorrect charging current
Double pulsing green	Inhibit mode	Switching into inhibit mode via controller
Green and red off	DC mode	Battery operation (emergency mode)

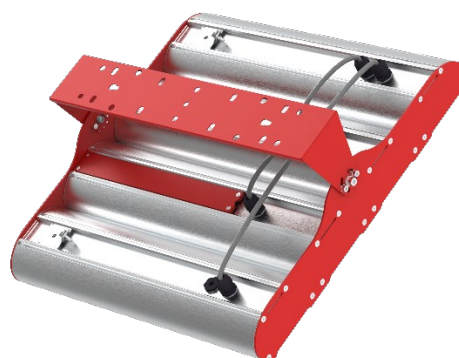

8.1 Testing

Commissioning test

- A full commissioning test is carried out automatically after permanent connection of the supply for 5 days. The easy commissioning feature will set the initial test day and time to ensure random testing of units.

Functional test

- Functional tests are carried out for 5 seconds on a weekly basis under the control of the Micro controller. Initiation and timing of these tests is set during the commissioning of the luminaire.

Duration test

- A full duration test is carried out yearly to check the capacity of the batteries. For a full description of commissioning and test features please refer to application notes.

9. CONDITIONS OF SAFETY USE

- Every light fitting must have label with rating data on it. Each light fitting is equipped with this „Installation and maintenance manual”, which must be kept by user until the end of exploitation.
- Light fittings are designed for fixed installations only.
- Using light fitting outside the designated operating temperature range is unacceptable and will decrease a lifetime of light fitting and/or damage it. It will also cause a loss of warranty.



Remark: Using light fitting beyond the designated operating temperature range may result in the loss of explosion protection measures, such as exceed temperature class and explosion.

- Each light fitting must have a warning sign: „DO NOT OPEN UNDER VOLTAGE” on it.
- Use power wires with cross section **1-4mm²**. Cross-section **1-6mm²** for special luminaire execution.
- Maximum cross current **I=16A**.
- Depending on the version, the diffuser is made of tempered glass or PC. Version with PC diffuser should not be exposed to chemicals that can damage it, in particular: oil, acetone, chlorine, ethyl, ether, solvents. If there is uncertainty about the substances present in the luminaire's work area that could lead to damage to any of the components, then determination

measures should be taken. Luminaires fitted with a PC diffuser shall carry the warning label "Caution! Risk of electrostatic charge" (see point 11).



- Do not stare into working light source.



- Risk of electrical shock.

10. CLEANING



Do not allow dust to accumulate on the light fitting. Cleaning have to be carried out using vacuum cleaners or a soft cloth with antistatic agent suitable to working conditions. Do not use chemicals that can damage any part of the light fitting.

11. REPAIRING AND EXCHANGE PARTS

All parts considered as a spare parts must be ordered at manufacturer of light fitting. Additionally, the replacement of the light source may be performed by ATM Lighting Sp. z o.o and specially trained personnel, using original components supplied by ATM Lighting Sp. z o.o.



All repairs may be made only by manufacturer or authorized repair workshops according to PN-EN 60079-19.

12. LIGHT SOURCE EXCHANGE

The light source used in this luminaire should be replaced only by the manufacturer or its service representative, or a similarly qualified person, using original components supplied by ATM Lighting sp.z o.o.

13. TRANSPORT AND CONDITIONS OF STORAGE

During transport light fittings shouldn't be exposed to precipitation or mechanical shock.

Light fittings may be storage only in sheltered warehouses, within +5°C to +35°C temperature range, and relative humidity lower than 75%. No corrosion causing vapors or gases should be present

14. DISPOSAL OF WASTE EQUIPMENT



User must obey relevant rules and regulations about disposal of wasted equipment valid in their country

15. WARRANTY

- It is forbidden to use a damaged or malfunctioning luminaire. Installation checks must be carried out to detect any anomalies.
- It is required to disconnect power supply from the light fitting before any maintenance work.
- It is forbidden to make any changes to the light fitting construction. Any unauthorized interference may result in reduced functionality or damage to the device and may in some cases endanger life or health. At the same time it relieves the manufacturer of all warranty liability.
- All specific information can be found in document „General terms and conditions warranty ATM Lighting sp. z o.o.” available at the website www.atmlighting.pl/en/

ADDRESS:

ATM Lighting sp. z o.o.

ul. Maszynowa 30A 80-298 Gdańsk

tel: +48 58 347 51 07 fax: +48 58 347 51 08

office@atmlighting.pl