



Our *passion* is enclosures.



# aluFACE

Command enclosures from cast aluminium

# A front plate enclosure from aluminium - for every application ...



aluFACE series KTE - secure connection technology in a separately opening connection space



aluFACE series KCE - flat front framework, two-part top section



The aluFACE series KVE - flat front framework, two-part top section, screwed



aluFACE series KVF - flat front framework, flat lower section, screwed

## aluFACE - this ROLEC enclosure series has many faces.

From aluminium. The front door comprises die-cast zinc corner pieces, which are mounted with extruded aluminium pressed profiles.

### Economy factor:

The economical screwed version of the KVE, KVF and KE series.

The KE series for example has a flat front framework as a single-piece aluminium frame. The aluminium front plate is easy to install without visible screws. Protection type IP 66.

The KTE series can be supplied with a series of cover variants. Protection type to IP 66.

Locks and hinges ease security and accessibility with the series KCE and KSE

In total, all enclosure variants together offer **66 enclosure sizes.**



aluFACE series KSE - high front framework,  
two-part top section

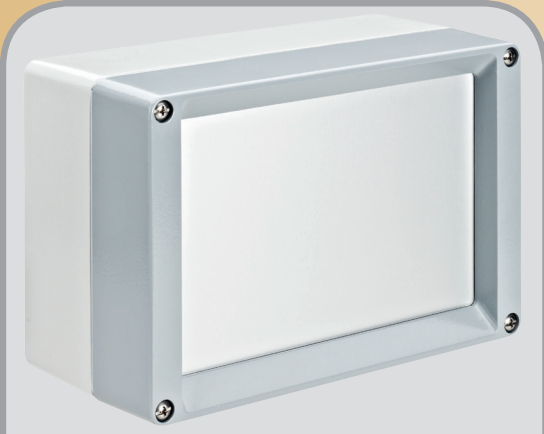

aluFACE series KE - flat front framework,  
single-part aluminium frame

"The principle of perfect alignment  
with the environment and the living  
space. Diversity of the species."

# Technical data

## aluFACE series KTE

### aluTWIN



KTE series



aluTWIN



Mounting rail and terminals



External mounting feet



Mounting plates

**Enclosure** with separate connection space and front frame:  
Die-cast aluminium: EN AN-44300 DIN EN 1706  
(GD AL SI 12 / DIN 1725) 1° mould slope  
for casting ejection, internal measures diminishing circulatory  
towards enclosure bottom by 1°.

**Fastening:** Space-saving single-channel technology

**Installation option:** Fastening thread M4/M6

**Front plate:** Aluminium 3mm, Al Mg 1, silver anodised

**Ingress Protection:** IP66 / EN 60529

**Front frame gasket:** TPE moulded gasket, silicone-free (-40°C  
to +120°C)

**Gasket:** connection space and front plate: Chloroprene (CR)  
gasket (-30°C to +90°C)

**Captive screws:** Stainless steel 1.4567 (V2A), captive

**Lid surface:** Powder coating, RAL 7040, window grey

**Enclosure bottom surface:** Powder coating RAL 7035, light grey

**Optionally available:**

**External mounting feet:** Die-cast zinc (Zn Al 4 Cu 1)

**Mounting plates:** Sheet steel, galvanised

**Gasket:** Silicone gasket (-50°C to +140°C)

**Surface:** Corrosion protection, special colours

**Further options, see delivery overview.**





Delivery overview aluFACE series KTE

Type	Mat. no.	L	W	H	D	E	F	g	M	S	D	HS
KTE 160	127.160.000	240	160	120	142	142	103	2.150	●	●	●	●
KTE 162	127.162.000	240	240	120	222	142	103	3.080	●	●	●	●



Delivery overview aluTWIN

Type	Mat. no.	L	W	H	D	E	F	g	M	D	A	L	T	S	DV	HS	EMC	67
ATF 100	105.100.000	166	100	55	87	87	40	730	●	●	●	●	●	○	○	○	●	●
AT 100	104.100.000	166	100	81	87	87	40	770	●	●	●	●	●	○	○	○	●	●
AT 160	104.160.000	240	160	103	142	142	103	2.170	●	●	●	●	●	●	●	●	●	●
AT 162	104.162.000	240	240	103	222	142	103	3.900	●	●	●	●	●	●	●	●	●	●



□ Standard ● Available ○ Not available

Approvals:

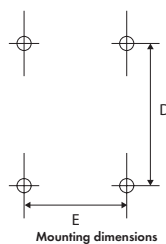
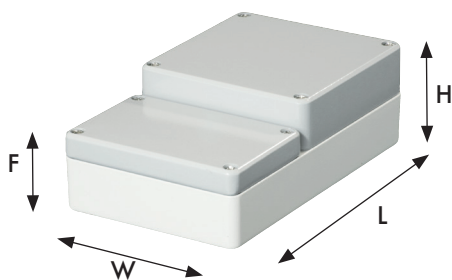

# Technical data

## aluFACE series KCE



KCE series



External mounting brackets



Handle system  
RAL 3020, traffic red



Handle system  
RAL 9005, deep black



Double-bit lock and  
hinge (on W side)



Optional suspension  
system taraPLUS

**Enclosure with flat front frame:** Die-cast aluminium EN AN-44300 DIN EN 1706 (GD AL SI 12 / DIN 1725). 1° mould slope for casting ejection, internal measures diminishing circulatory towards enclosure bottom by 1°.

**Fastening:** Space-saving single-channel technology

**Installation option:** Fastening thread M6

**Front frame:** Corner pieces die-cast zinc, (Zn Al 4 Cu 1) aluminium profile, (Al Mg Si 0.5)

**Front plate:** Aluminium 3mm, Al Mg 1, silver anodised

**Ingress Protection:** IP65 / EN 60529

**Enclosure gasket:** TPE moulded gasket, silicone-free (-40°C to +120°C) Chloroprene (CR) gasket (-30°C to +90°C)

**Front plate gasket:** Chloroprene (CR) gasket (-30°C to +90°C)

**Closure:** Lock and hinge, narrow side (side W)

**Front frame and enclosure lid surface:** Powder coating, RAL

7040, window grey

**Enclosure bottom surface:** Powder coating RAL 7035, light grey

**Optionally available:**

**Fastening:** Support system taraPLUS

**External mounting brackets:** Die-cast zinc (Zn Al 4 Cu 1)

**Mounting plates:** Sheet steel, galvanised

**Gasket:** Silicone gasket (-50°C to +140°C)

**Handle system:** Steel tube, power coated RAL 3020, traffic red RAL 9005, deep black

**Closure:** Lock and hinge, long side (side L)

**Surface:** Corrosion protection, special colours

**Further options, see delivery overview.**



**Delivery overview aluFACE series KCE**

Type	Mat. no.	L	W	H	D	E	g	M	S	DV	W	X	Y	Z	J	I
KCE 120	119.120.000	120	120	114	102	102	1590	●	□	□	●	●	●	●	○	○
KCE 122	119.122.000	180	120	114	162	102	1820	●	□	□	●	●	●	●	○	○
KCE 124	119.124.000	240	120	114	222	102	2170	●	□	□	●	●	●	●	○	○
KCE 160	119.160.000	160	160	114	142	142	2060	●	□	□	●	●	●	●	●	○
KCE 162	119.162.000	240	160	114	222	142	2650	●	□	□	●	●	●	●	●	○
KCE 164	119.164.000	320	160	114	302	142	3190	●	□	□	●	●	●	●	●	○
KCE 166	119.166.000	480	160	114	462	142	4710	●	□	□	●	●	●	●	●	○
KCE 200	119.200.000	200	200	135	180	180	3150	●	□	□	●	●	●	●	●	●
KCE 202	119.202.000	300	200	135	280	180	3680	●	□	□	●	●	●	●	●	●
KCE 204	119.204.000	400	200	135	380	180	5480	●	□	□	●	●	●	●	●	●
KCE 240	119.240.000	240	240	135	220	220	4110	●	□	□	●	●	●	●	●	●
KCE 242	119.242.000	360	240	135	340	220	4800	●	□	□	●	●	●	●	●	●
KCE 244	119.244.000	480	240	135	460	220	6950	●	□	□	●	●	●	●	●	●
KCE 320	119.320.000	320	320	135	300	300	5720	●	□	□	●	●	●	●	●	●
KCE 322	119.322.000	480	320	135	460	300	7530	●	□	□	●	●	●	●	●	●
KCE 324	119.324.000	640	320	135	620	300	9720	●	□	□	●	●	●	●	●	●

□ Standard ● Available ○ Not available

Approvals:

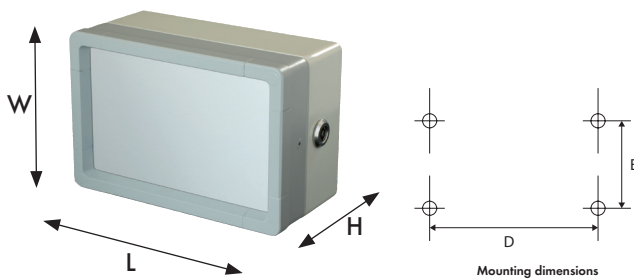

# Technical data

## aluFACE series KSE



**Enclosure with high front frame:** Die-cast aluminium EN AN-44300 DIN EN 1706 (GD AL SI 12 / DIN 1725). 1° mould slope for casting ejection, internal measures diminishing circulatory towards enclosure bottom by 1°.

**Fastening:** Space-saving single-channel technology

**Installation option:** Fastening thread M6

**Front frame:** Corner pieces die-cast zinc, (Zn Al 4 Cu 1) aluminium profile, (Al Mg Si 0.5)

**Front plate:** Aluminium 3mm, Al Mg 1, silver anodised

**Ingress Protection:** IP65 / EN 60529

**Enclosure gasket:** TPE moulded gasket, silicone-free (-40°C to +120°C) Chloroprene (CR) gasket (-30°C to +90°C)

**Front plate gasket:** Chloroprene (CR) gasket (-30°C to +90°C)

**Closure:** Lock and hinge, narrow side (side W)

**Front frame surface:** Powder coating, RAL 7040, window grey

**Enclosure surface:** Powder coating RAL 7035, light grey

**Optionally available:**

**Fastening:** Support system taraPLUS

**External mounting brackets:** Die-cast zinc (Zn Al 4 Cu 1)

**Mounting plates:** Sheet steel, galvanised

**Gasket:** Silicone gasket (-50°C to +140°C)

**Handle system:** Steel tube, power coated RAL 3020, traffic red RAL 9005, deep black

**Closure:** Lock and hinge, long side (side L)

**Surface:** Corrosion protection, special colours

**Further options, see delivery overview.**





**Delivery overview aluFACE series KSE**

Type	Mat. no.	L	W	H	D	E	g	M	S	DV	W	X	Y	Z	J	I
KSE 160	115.160.000	160	160	133,5	142	142	2360	●	□	□	●	●	●	●	●	○
KSE 162	115.162.000	240	160	133,5	222	142	2960	●	□	□	●	●	●	●	●	○
KSE 164	115.164.000	320	160	133,5	302	142	3530	●	□	□	●	●	●	●	●	○
KSE 166	115.166.000	480	160	133,5	462	142	5090	●	□	□	●	●	●	●	●	○
KSE 200	115.200.000	200	200	153,5	180	180	3460	●	□	□	●	●	●	●	●	●
KSE 202	115.202.000	300	200	153,5	280	180	4320	●	□	□	●	●	●	●	●	●
KSE 204	115.204.000	400	200	153,5	380	180	5860	●	□	□	●	●	●	●	●	●
KSE 240	115.240.000	240	240	153,5	220	220	4450	●	□	□	●	●	●	●	●	●
KSE 242	115.242.000	360	240	153,5	340	220	5160	●	□	□	●	●	●	●	●	●
KSE 244	115.244.000	480	240	153,5	460	220	7350	●	□	□	●	●	●	●	●	●
KSE 320	115.320.000	320	320	153,5	300	300	6100	●	□	□	●	●	●	●	●	●
KSE 322	115.322.000	480	320	153,5	460	300	7950	●	□	□	●	●	●	●	●	●
KSE 324	115.324.000	640	320	153,5	620	300	10180	●	□	□	●	●	●	●	●	●

□ Standard ● Available ○ Not available

Approvals:

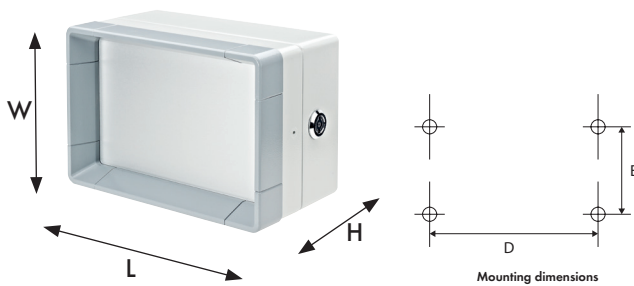

# Technical data

## aluFACE series KVE



**Enclosure with flat front frame:** Die-cast aluminium EN AN-44300 DIN EN 1706 (GD AL SI 12 / DIN 1725) .1° mould slope for casting ejection, internal measures diminishing circulatory towards enclosure bottom by 1°.

**Fastening:** Space-saving single-channel technology

**Installation option:** Fastening thread M6

**Front frame:** Corner pieces die-cast zinc, (Zn Al 4 Cu 1) aluminium profile, (Al Mg Si 0.5)

**Front plate:** Aluminium 3mm, Al Mg 1, silver anodised

**Ingress Protection:** IP65 / EN 60529

**Enclosure gasket:** TPE moulded gasket, silicone-free (-40°C to +120°C) Chloroprene (CR) gasket (-30°C to +90°C)

**Front plate gasket:** Chloroprene (CR) gasket (-30°C to +90°C)

**Captive screws:** Stainless steel 1.4567 (V2A), captive

**Front frame and enclosure lid surface:** Powder coating, RAL 7040, window grey

**Enclosure bottom surface:** Powder coating RAL 7035, light grey

**Optionally available:**

**Fastening:** Support system taraPLUS

**External mounting brackets:** Die-cast zinc (Zn Al 4 Cu 1)

**Mounting plates:** Sheet steel, galvanised

**Gasket:** Silicone gasket (-50°C to +140°C)

**Handle system:** Steel tube, power coated RAL 3020, traffic red RAL 9005, deep black

**Closure:** Lock and hinge, long side (side L)

**Surface:** Corrosion protection, special colours

**Further options, see delivery overview.**



**Delivery overview aluFACE series KVE**

Type	Mat. no.	L	W	H	D	E	g	M	S	HS	J	I
KVE 120	125.120.000	120	120	114	102	102	1390	●	●	●	○	○
KVE 122	125.122.000	180	120	114	162	102	1610	●	●	●	○	○
KVE 124	125.124.000	240	120	114	222	102	1970	●	●	●	○	○
KVE 160	125.160.000	160	160	114	142	142	1860	●	●	●	●	○
KVE 162	125.162.000	240	160	114	222	142	2440	●	●	●	●	○
KVE 164	125.164.000	320	160	114	302	142	2990	●	●	●	●	○
KVE 166	125.166.000	480	160	114	462	142	4500	●	●	●	●	○
KVE 200	125.200.000	200	200	135	180	180	2950	●	●	●	●	●
KVE 202	125.202.000	300	200	135	280	180	3470	●	●	●	●	●
KVE 204	125.204.000	400	200	135	380	180	5270	●	●	●	●	●
KVE 240	125.240.000	240	240	135	220	220	3900	●	●	●	●	●
KVE 242	125.242.000	360	240	135	340	220	4600	●	●	●	●	●
KVE 244	125.244.000	480	240	135	460	220	6740	●	●	●	●	●
KVE 320	125.320.000	320	320	135	300	300	5510	●	●	●	●	●
KVE 322	125.322.000	480	320	135	460	300	7320	●	●	●	●	●
KVE 324	125.324.000	640	320	135	620	300	9510	●	●	●	●	●

□ Standard ● Available ○ Not available

Approvals:

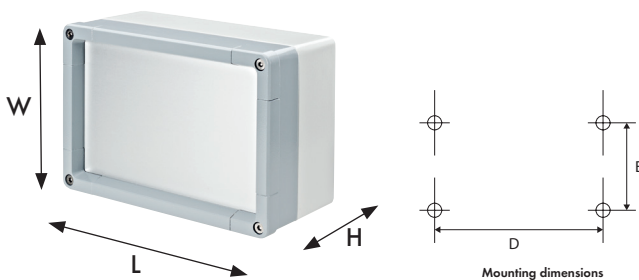

# Technical data

## aluFACE series KVF



KVF series



External mounting brackets



Handle system  
RAL 3020, traffic red



Handle system  
RAL 9005, deep black



Economical version with  
screwed front frame

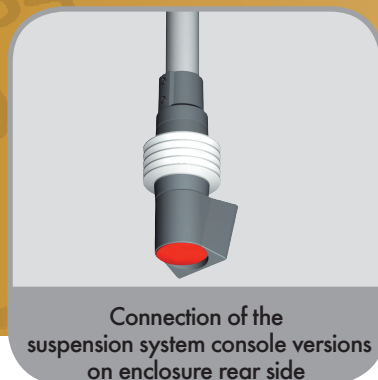

Connection of the  
suspension system console versions  
on enclosure rear side

**Enclosure with flat front frame:** Die-cast aluminium: EN AN-44300 DIN EN 1706 (GD AL SI 12 / DIN 1725). 1° mould slope for casting ejection, internal measures diminishing circulatory towards enclosure bottom by 1°.

**Fastening:** Space-saving single-channel technology

**Installation option:** Fastening thread M6

**Front frame:** Corner pieces die-cast zinc, (Zn Al 4 Cu 1) aluminium profile, (Al Mg Si 0.5)

**Front plate:** Aluminium 3mm, Al Mg 1, silver anodised

**Ingress Protection:** IP65 / EN 60529

**Enclosure gasket:** TPE moulded gasket, silicone-free (-40°C to +120°C) Chloroprene (CR) gasket (-30°C to +90°C)

**Front plate gasket:** Chloroprene (CR) gasket (-30°C to +90°C)

**Captive screws:** Stainless steel 1.4567 (V2A), captive

**Front frame and enclosure lid surface:** Powder coating, RAL 7040, window grey

**Enclosure bottom surface:** Powder coating RAL 7035, light grey

**Optionally available:**

**Fastening:** Support system taraPLUS

**External mounting brackets:** Die-cast zinc (Zn Al 4 Cu 1)

**Mounting plates:** Sheet steel, galvanised

**Gasket:** Silicone gasket (-50°C to +140°C)

**Handle system:** Steel tube, power coated RAL 3020, traffic red RAL 9005, deep black

**Closure:** Lock and hinge, long side (side L)

**Surface:** Corrosion protection, special colours

**Further options, see delivery overview.**



**Delivery overview aluFACE series KVF**

Type	Mat. no.	L	W	H	D	E	g	M	S	HS	J
KVF 120	123.120.000	120	120	80	102	102	1200	●	●	●	○
KVF 122	123.122.000	180	120	80	162	102	1400	●	●	●	○
KVF 124	123.124.000	240	120	80	222	102	1690	●	●	●	○
KVF 160	123.160.000	160	160	80	142	142	1740	●	●	●	●
KVF 162	123.162.000	240	160	80	222	142	2230	●	●	●	●
KVF 164	123.164.000	320	160	80	302	142	2700	●	●	●	●
KVF 166	123.166.000	480	160	80	462	142	3990	●	●	●	●
KVF 200	123.200.000	200	200	95	180	180	2640	●	●	●	●
KVF 202	123.202.000	300	200	95	280	180	3350	●	●	●	●
KVF 204	123.204.000	400	200	95	380	180	4620	●	●	●	●
KVF 240	123.240.000	240	240	95	220	220	3460	●	●	●	●
KVF 242	123.242.000	360	240	95	340	220	4950	●	●	●	●
KVF 244	123.244.000	480	240	95	460	220	5850	●	●	●	●
KVF 320	123.320.000	320	320	95	300	300	4820	●	●	●	●
KVF 322	123.322.000	480	320	95	460	300	6340	●	●	●	●
KVF 324	123.324.000	640	320	95	620	300	8170	●	●	●	●

□ Standard ● Available ○ Not available

Approvals:

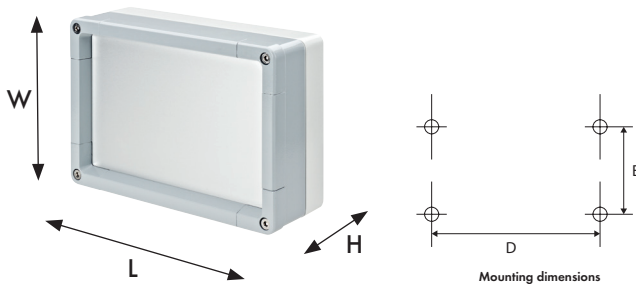

# Technical data

## aluFACE series KE

ADI 180



KE series



External mounting brackets

ADI 240

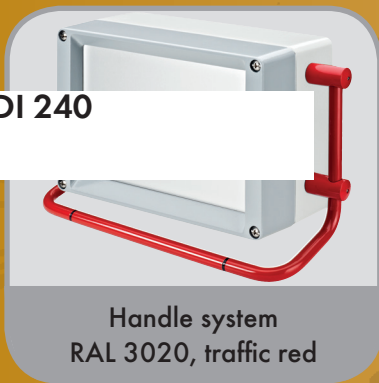

Handle system  
RAL 3020, traffic red



Handle system  
RAL 9005, deep black

ADI 300



Economical version with  
screwed front frame



Optional suspension  
system taraPLUS

**Enclosure with front frame:** Die-cast aluminium EN AN-44300 DIN EN 1706 (GD AL SI 12 / DIN 1725) 1° mould slope for casting ejection, internal measures diminishing circulatory towards enclosure bottom by 1°

**Fastening:** Space-saving single-channel technology

**Installation option:** Fastening thread M6

**Front frame:** Corner pieces die-cast zinc, (Zn Al 4 Cu 1) aluminium profile, (Al Mg Si 0.5)

**Front plate:** Aluminium 3mm, Al Mg 1, silver anodised

**Ingress Protection:** IP66 / EN 60529

**Front frame gasket:** TPE moulded gasket, silicone-free (-40°C to +120°C) Chloroprene (CR) gasket (-30°C to +90°C)

**Front plate gasket:** Chloroprene (CR) gasket (-30°C to +90°C)

**Captive screws:** Stainless steel 1.4567 (V2A), captive

**Lid surface:** Powder coating, RAL 7040, window grey

**Enclosure bottom surface:** Powder coating RAL 7035, light grey

### Optionally available:

**Fastening:** Support system taraPLUS

**External mounting brackets:** Die-cast zinc (Zn Al 4 Cu 1)

**Mounting plates:** Sheet steel, galvanised

**Gasket:** Silicone gasket (-50°C to +140°C)

**Handle system:** Steel tube, power coated  
RAL 3020, traffic red  
RAL 9005, deep black

**Closure:** Lock and hinge, long side (side L)

**Surface:** Corrosion protection, special colours

**Further options, see delivery overview.**



**Delivery overview aluFACE series KE**

Type	Mat. no.	L	W	H	D	E	g	M	S	V	W	X	Y	Z	J	I	D	HS
KE 160	126.160.000	160	160	117	142	142	1330	●	●	●	●	●	●	●	●	○	●	●
KE 162	126.162.000	240	160	117	222	142	1920	●	●	●	●	●	●	●	●	○	●	●
KE 242	126.242.000	360	240	137	340	220	4600	●	●	●	●	●	●	●	●	●	●	●

□ Standard ● Available ○ Not available

Approvals:

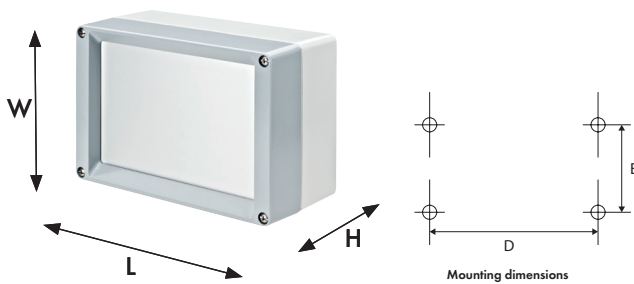

# ROLEC Attachment and mounting dimensions

## aluFACE

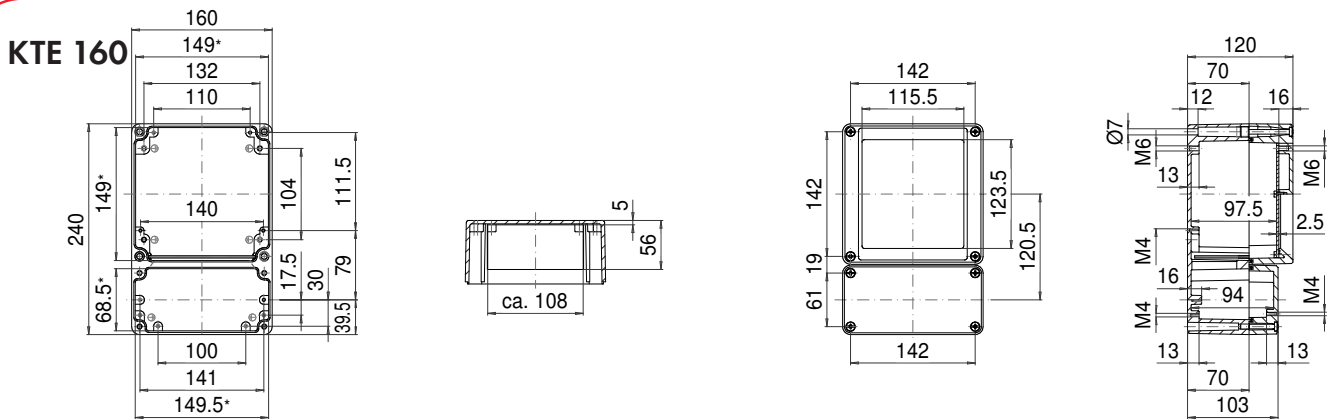

\* Please note: Mould slope for casting ejection, dimensions in the amount of the bottom!

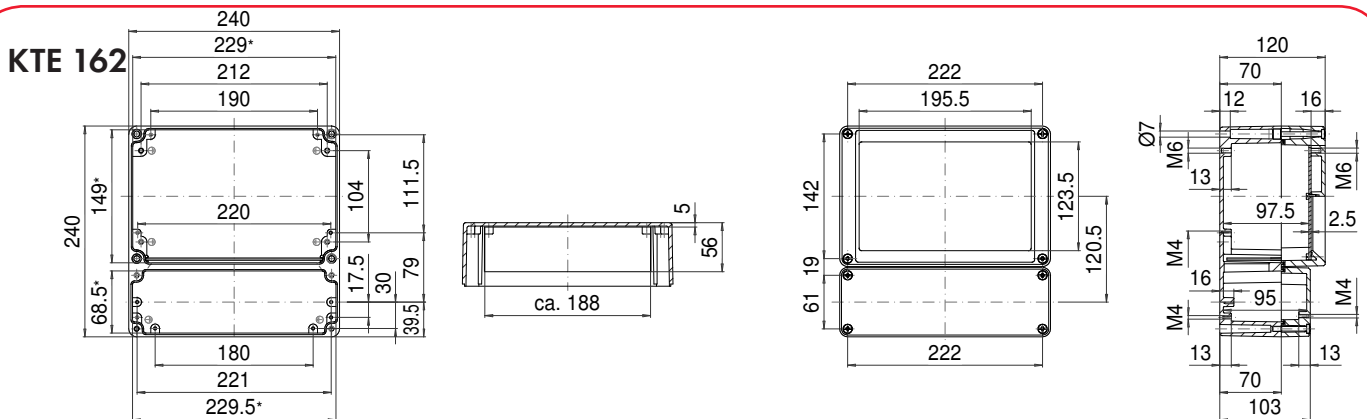

\* Please note: Mould slope for casting ejection, dimensions in the amount of the bottom!

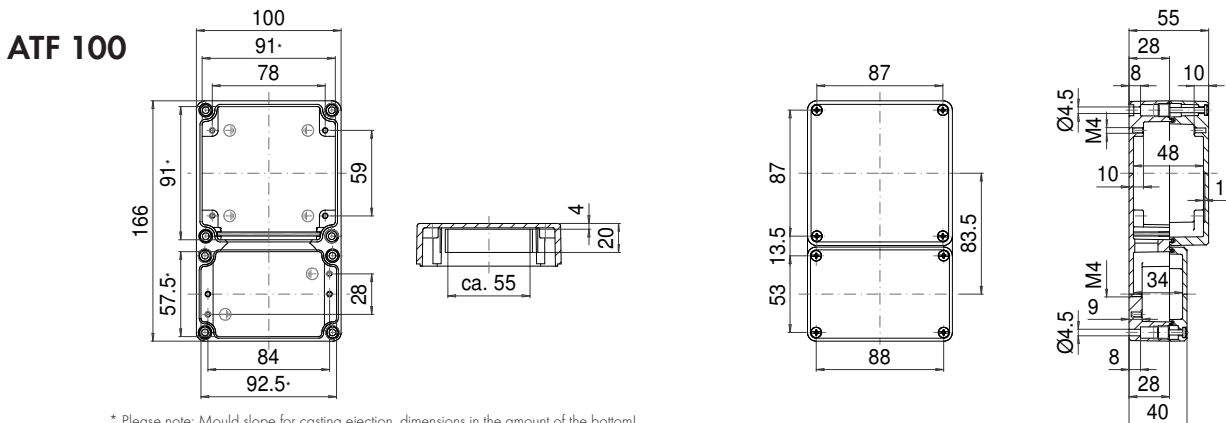

\* Please note: Mould slope for casting ejection, dimensions in the amount of the bottom!

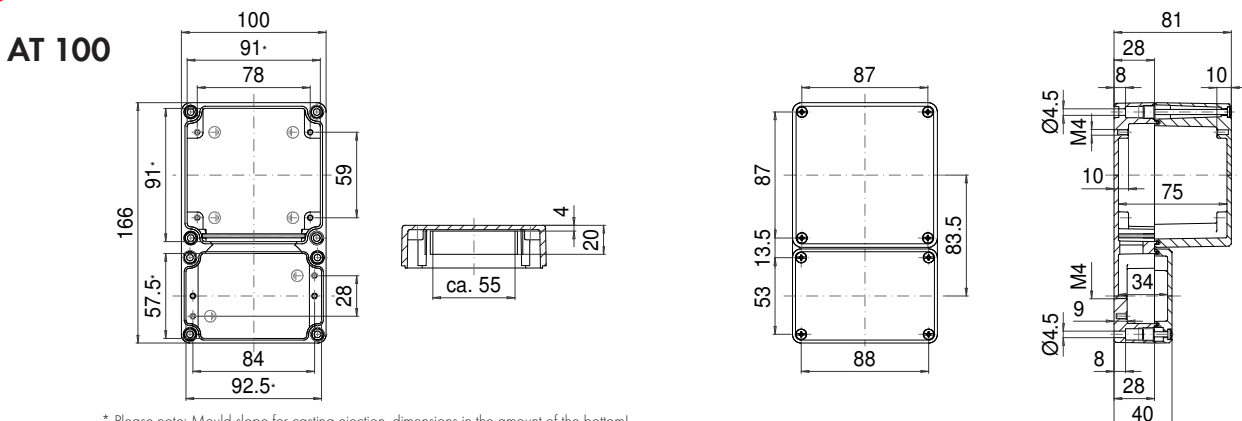

\* Please note: Mould slope for casting ejection, dimensions in the amount of the bottom!



### AT 160

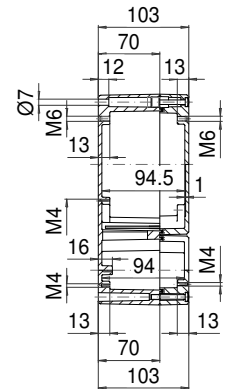
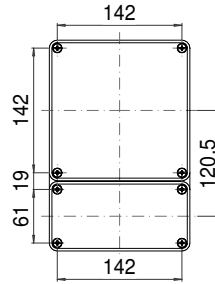
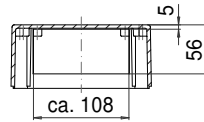
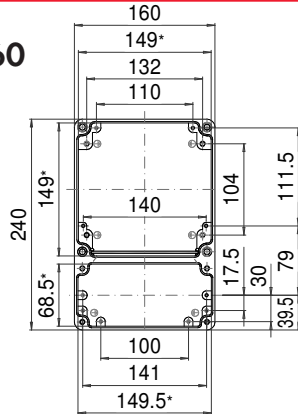

\* Please note: Mould slope for casting ejection, dimensions in the amount of the bottom!

### AT 162

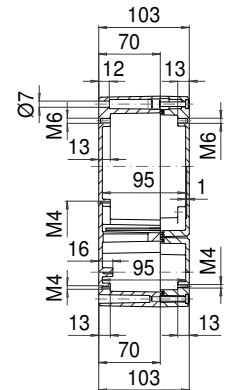
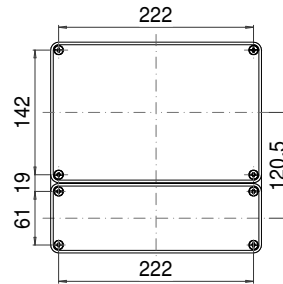
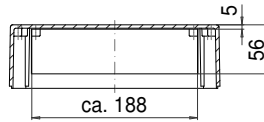
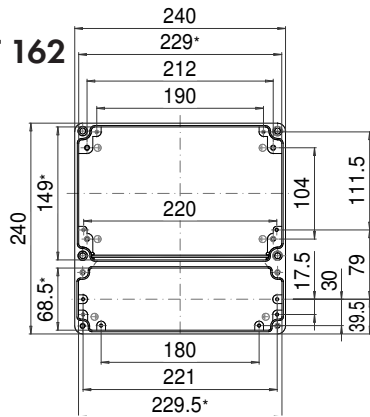

\* Please note: Mould slope for casting ejection, dimensions in the amount of the bottom!

### KE 160

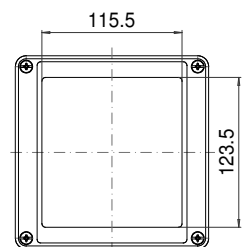
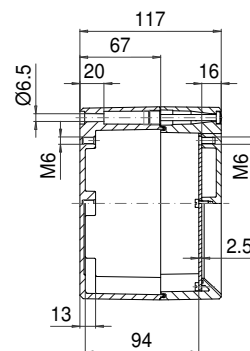
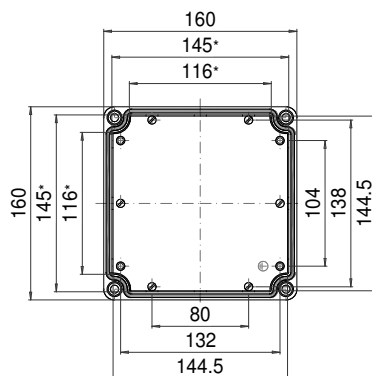
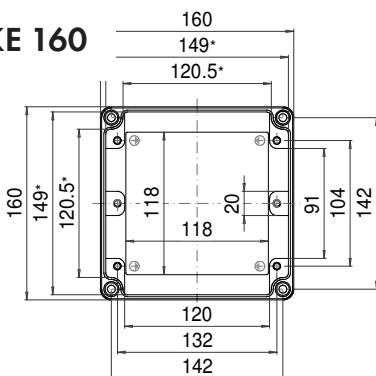

\* Please note: Mould slope for casting ejection, dimensions in the amount of the bottom!

# ROLEC Attachment and mounting dimensions

## aluFACE

### KE 162

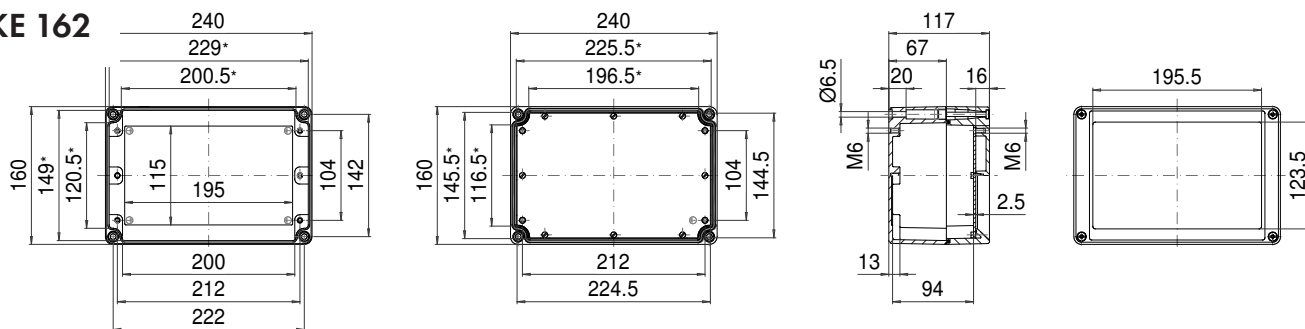

\* Please note: Mould slope for casting ejection, dimensions in the amount of the bottom!

### KE 242

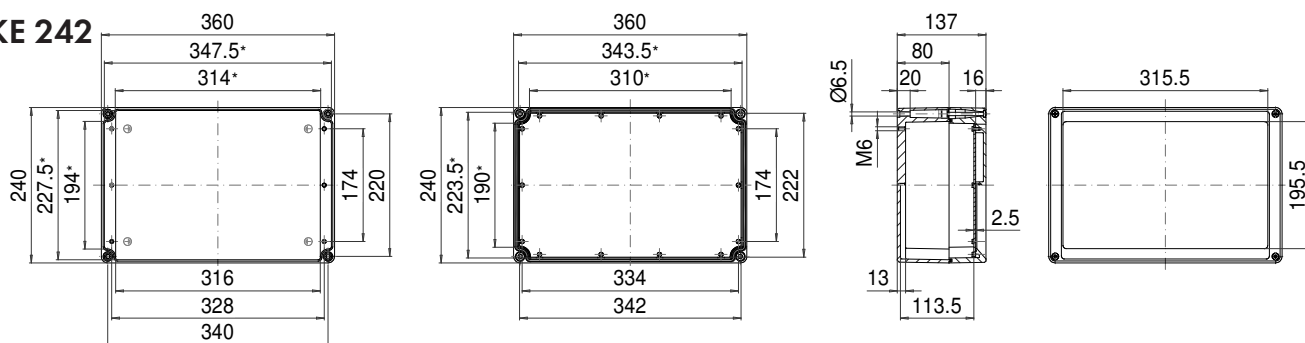

\* Please note: Mould slope for casting ejection, dimensions in the amount of the bottom!

### KVF 120

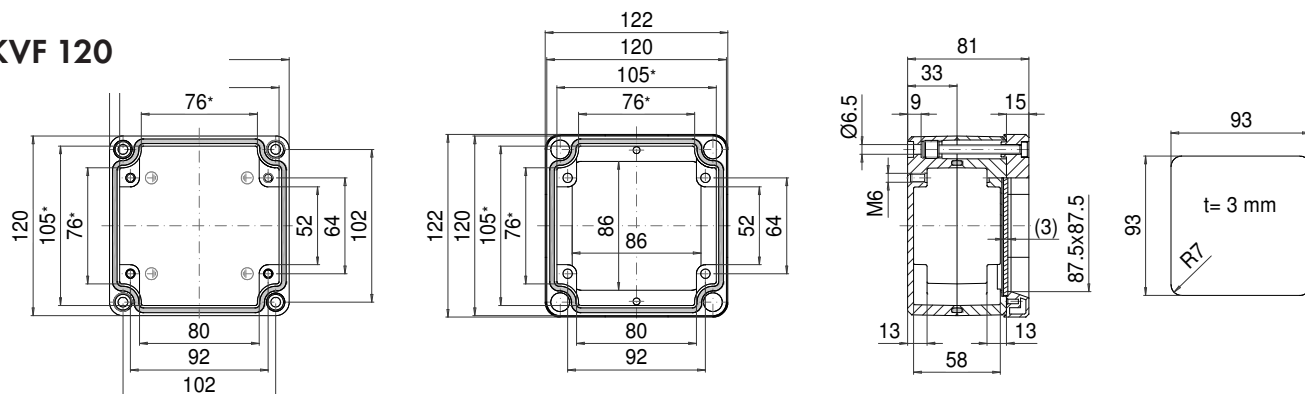

\* Please note: Mould slope for casting ejection, dimensions in the amount of the bottom!

### KCE 120

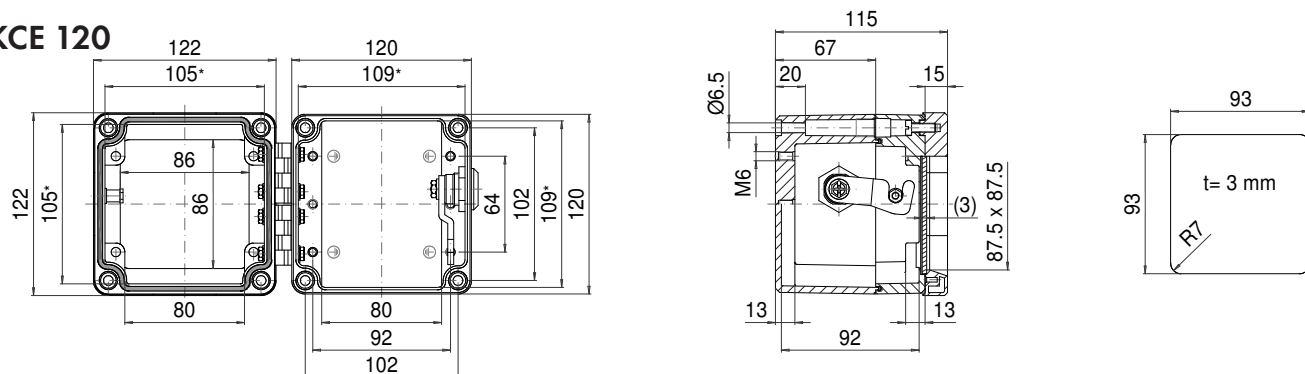

\* Please note: Mould slope for casting ejection, dimensions in the amount of the bottom!

### KVF 122

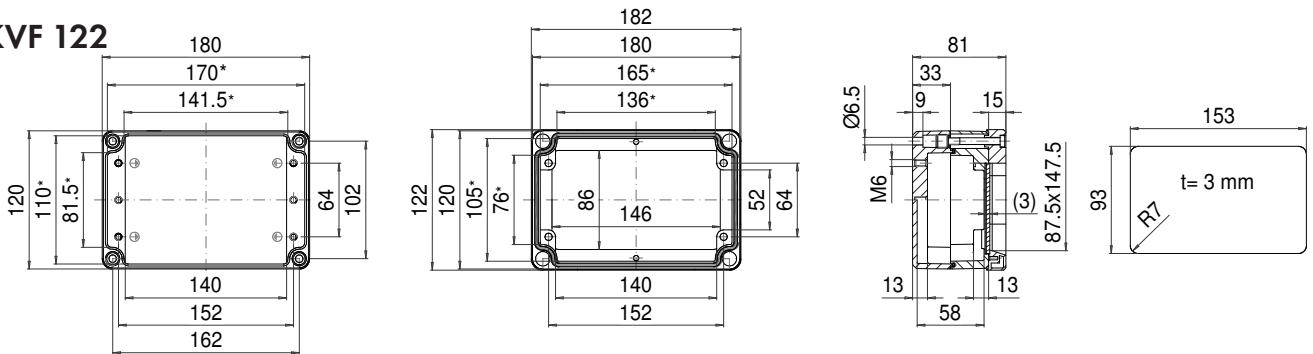

\* Please note: Mould slope for casting ejection, dimensions in the amount of the bottom!

### KCE 122

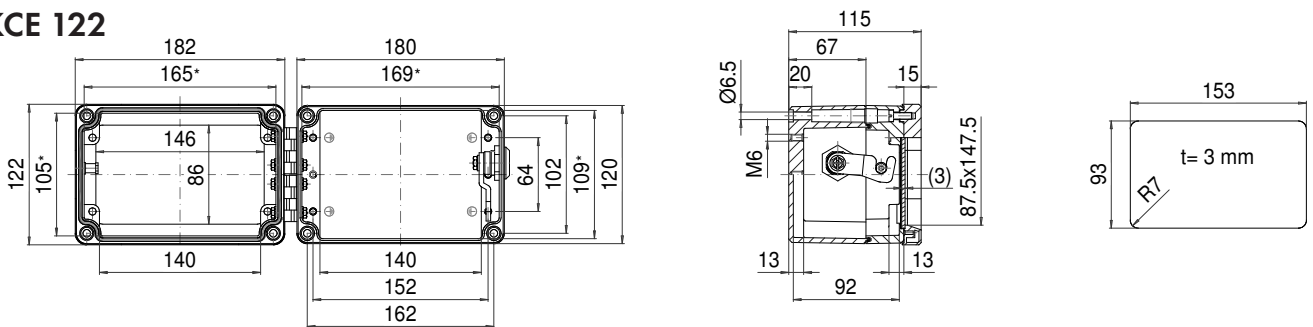

\* Please note: Mould slope for casting ejection, dimensions in the amount of the bottom!

### KVF 124

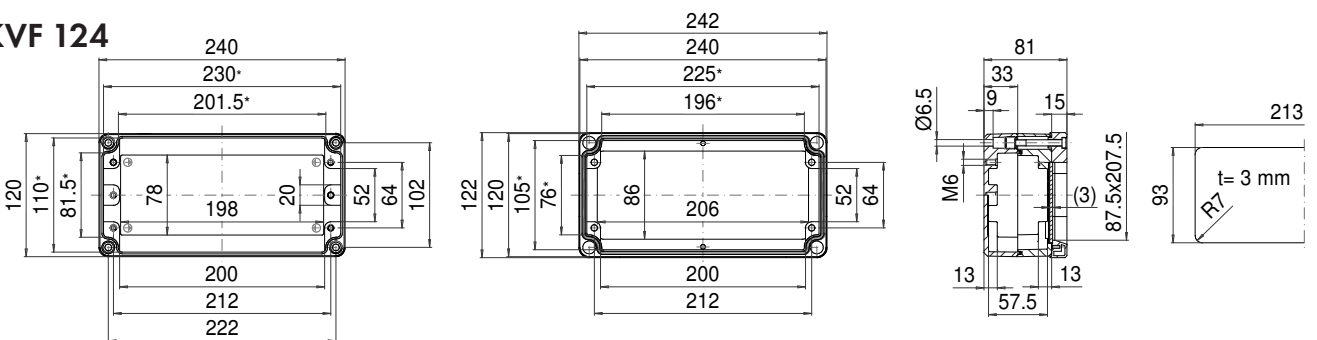

\* Please note: Mould slope for casting ejection, dimensions in the amount of the bottom!

### KCE 124

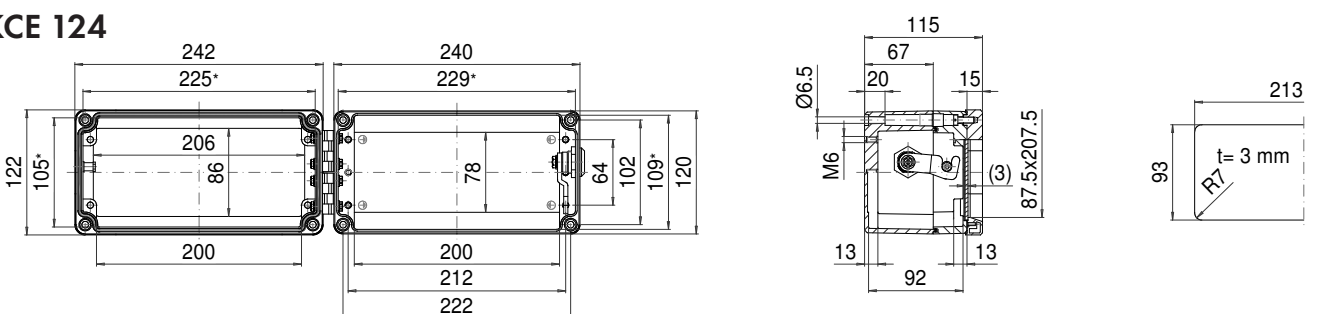

\* Please note: Mould slope for casting ejection, dimensions in the amount of the bottom!







# ROLEC Attachment and mounting dimensions

## aluFACE

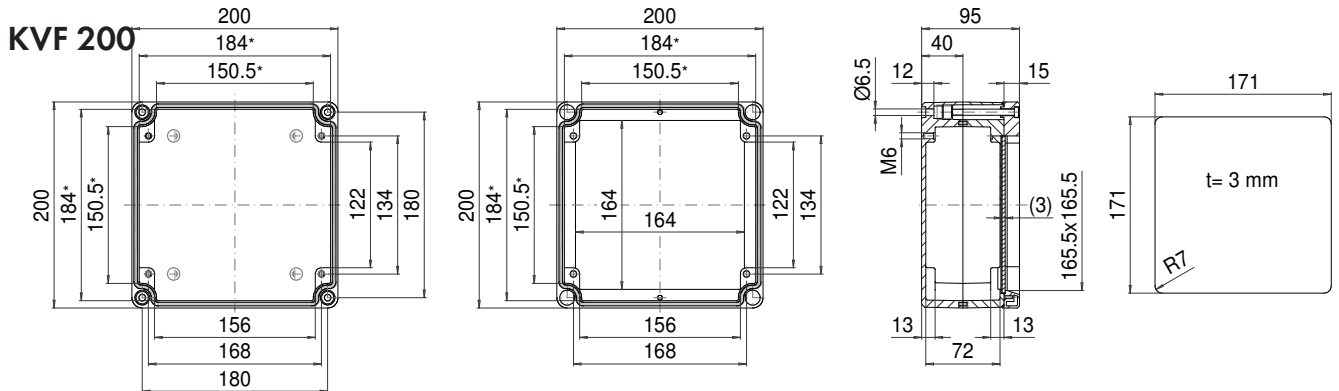

\* Please note: Mould slope for casting ejection, dimensions in the amount of the bottom!

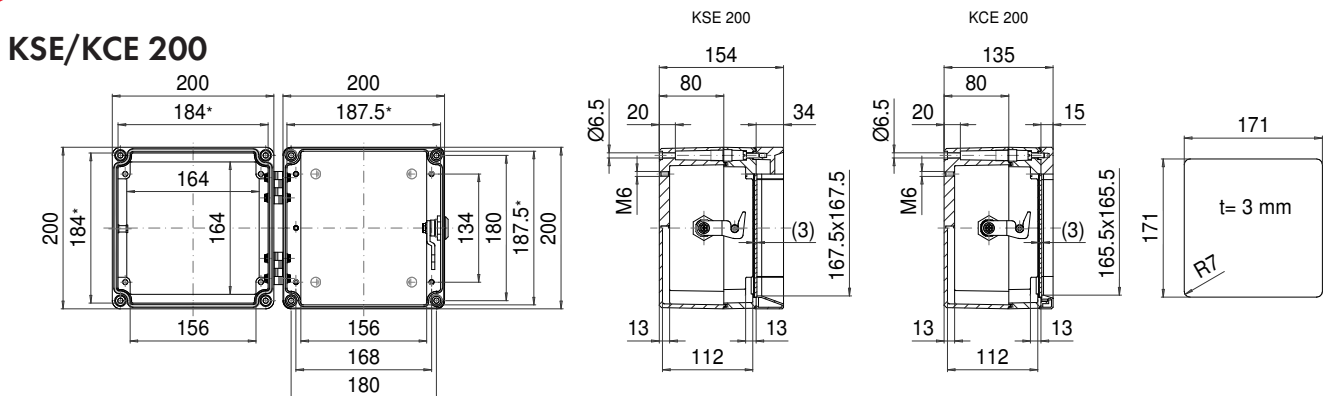

\* Please note: Mould slope for casting ejection, dimensions in the amount of the bottom!

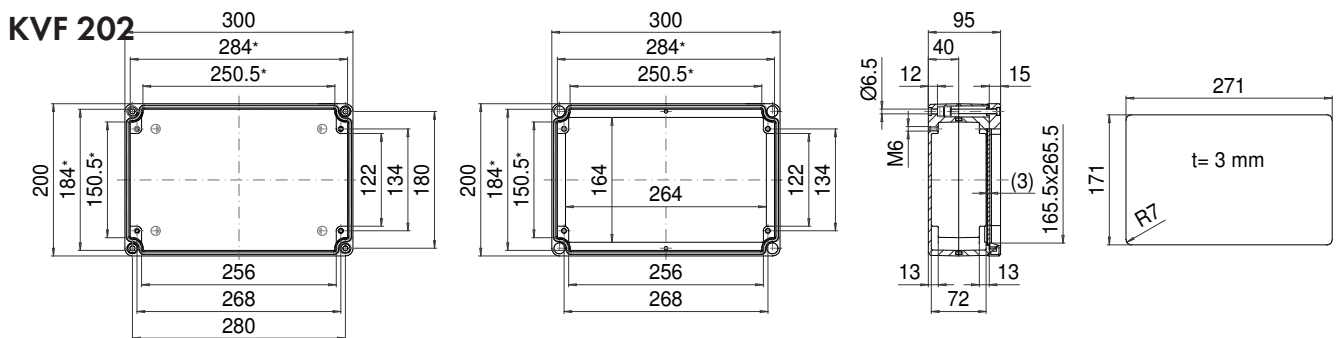

\* Please note: Mould slope for casting ejection, dimensions in the amount of the bottom!

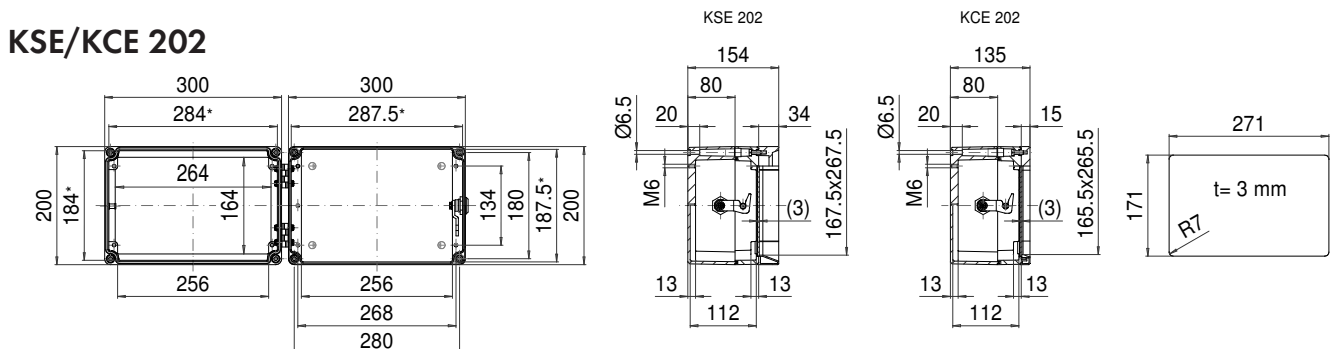

\* Please note: Mould slope for casting ejection, dimensions in the amount of the bottom!

### KVF 204

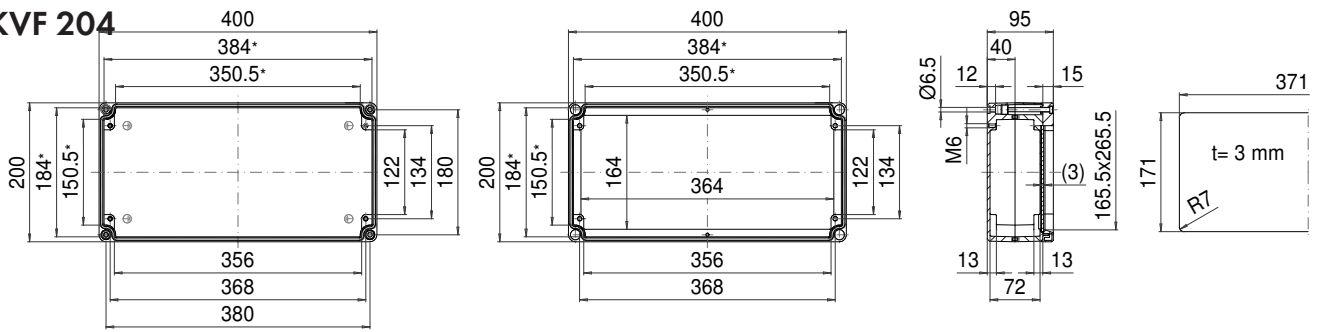

\* Please note: Mould slope for casting ejection, dimensions in the amount of the bottom!

### KSE/KCE 204

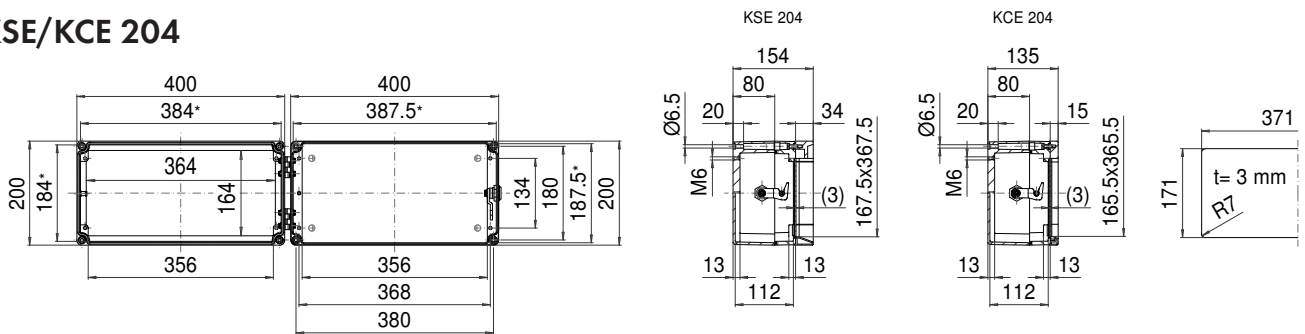

\* Please note: Mould slope for casting ejection, dimensions in the amount of the bottom!

### KVF 240

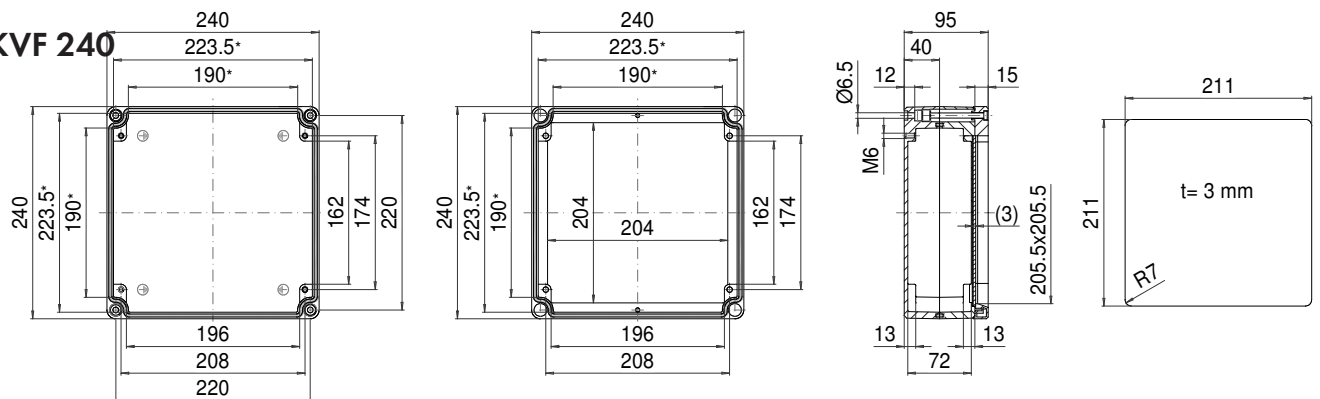

\* Please note: Mould slope for casting ejection, dimensions in the amount of the bottom!

### KSE/KCE 240

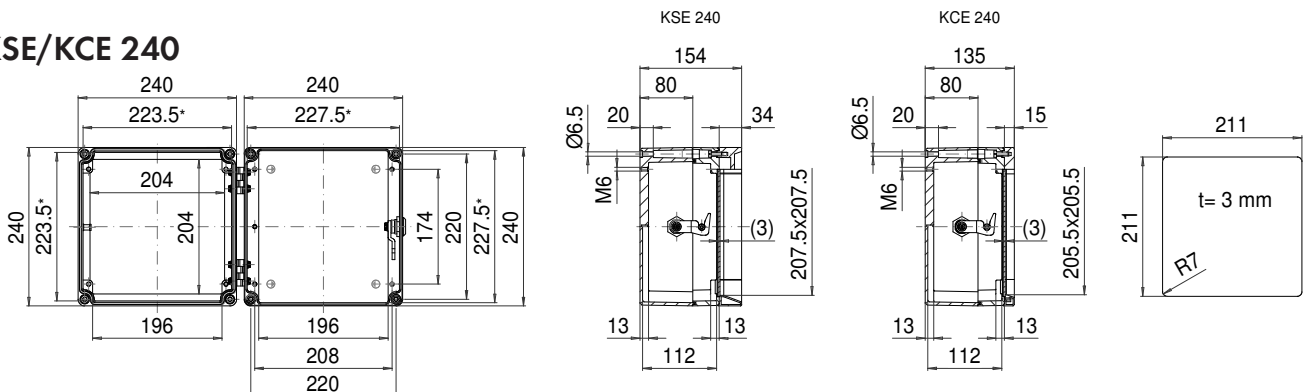

\* Please note: Mould slope for casting ejection, dimensions in the amount of the bottom!

# ROLEC Attachment and mounting dimensions

## aluFACE

### KVF 242

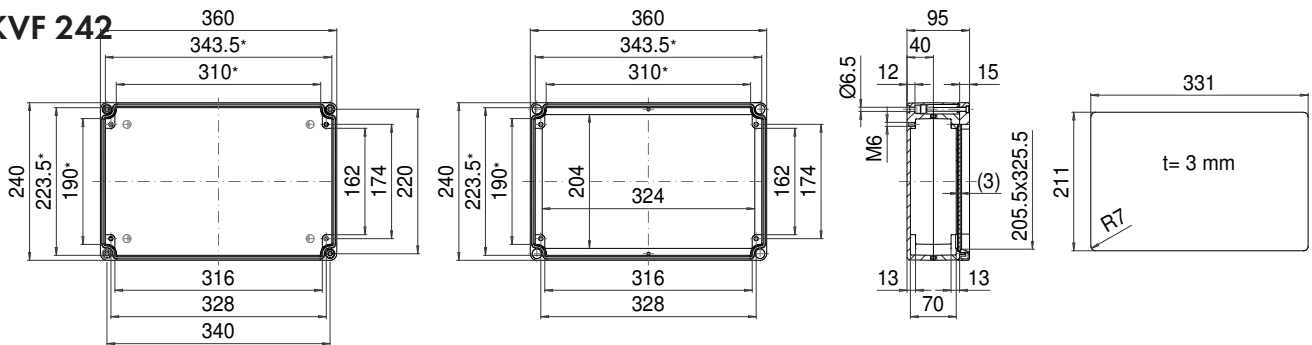

\* Please note: Mould slope for casting ejection, dimensions in the amount of the bottom!

### KSE/KCE 242

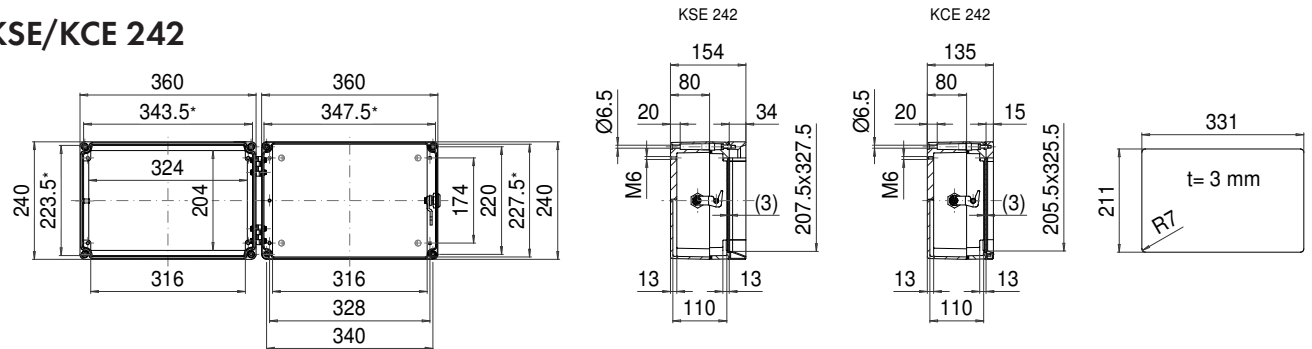

\* Please note: Mould slope for casting ejection, dimensions in the amount of the bottom!

### KVF 244

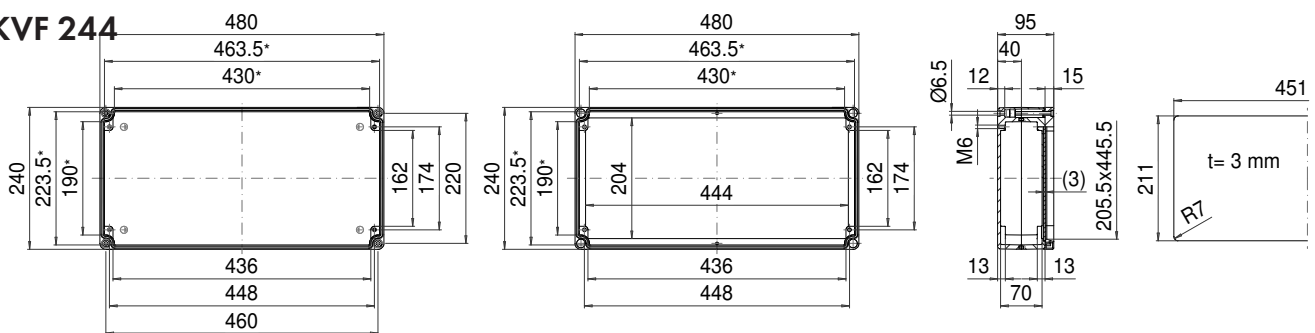

\* Please note: Mould slope for casting ejection, dimensions in the amount of the bottom!

### KSE/KCE 244

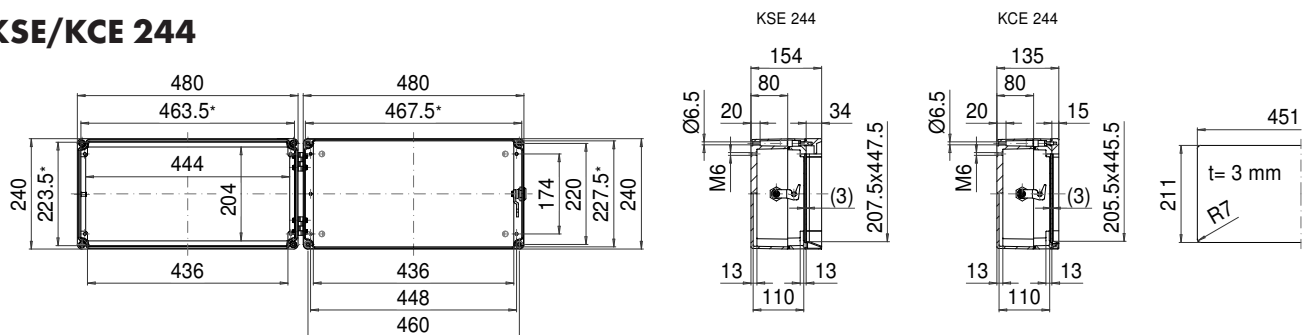

\* Please note: Mould slope for casting ejection, dimensions in the amount of the bottom!

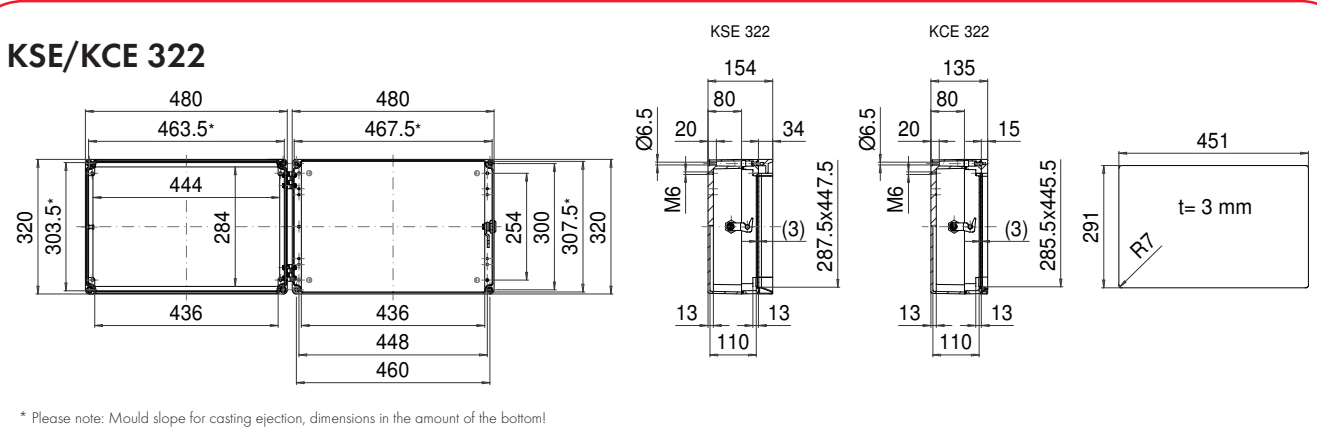
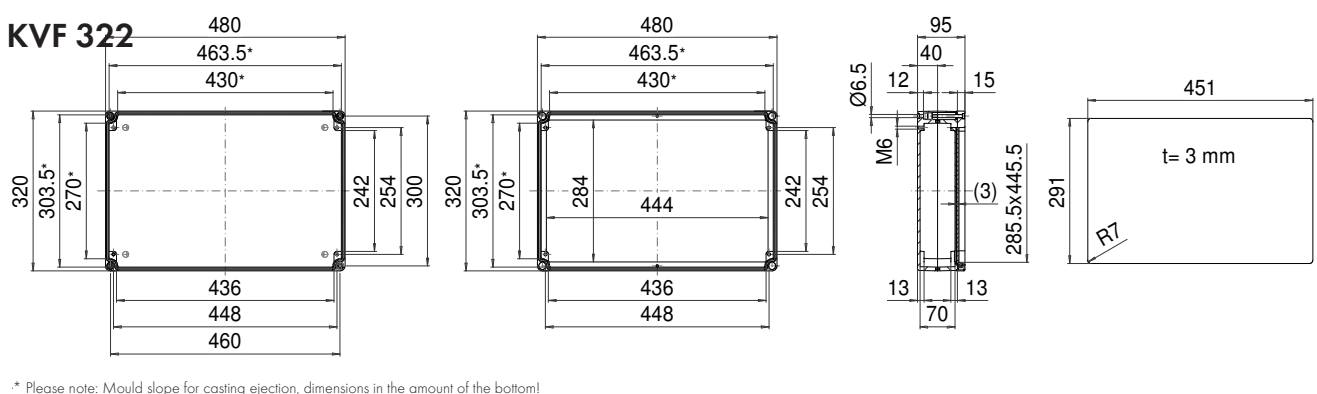
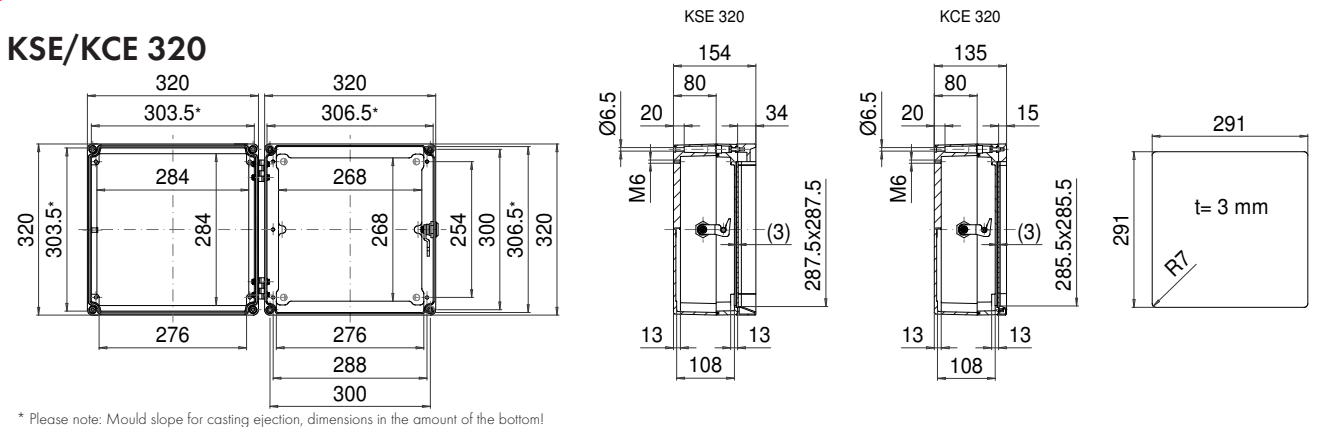
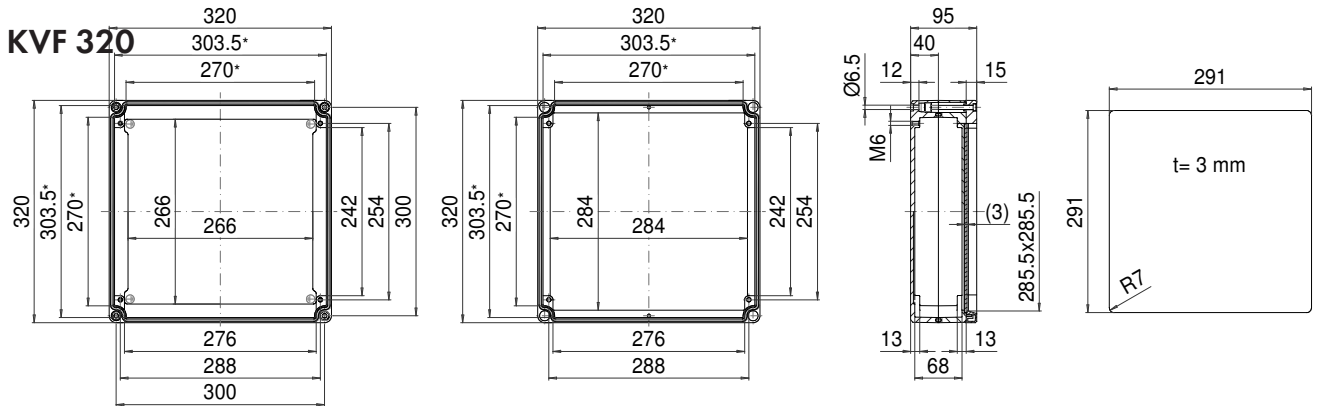

### KVF 324

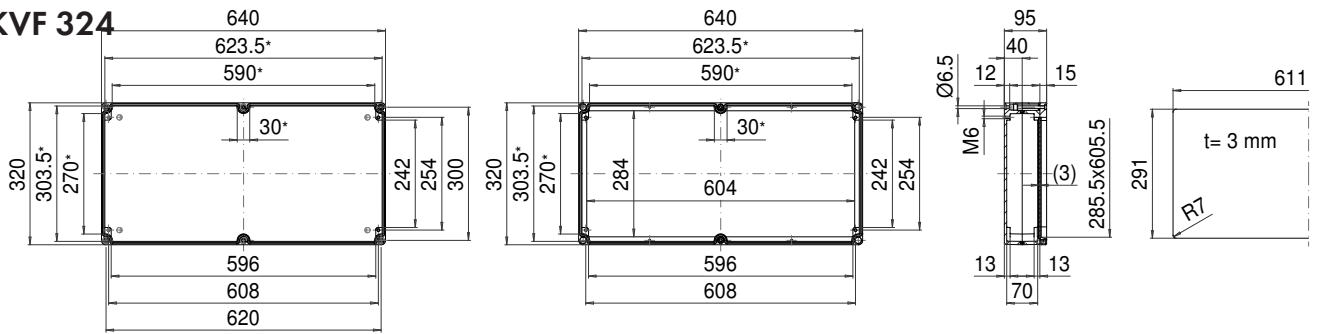

\* Please note: Mould slope for casting ejection, dimensions in the amount of the bottom!

### KSE/KCE 324

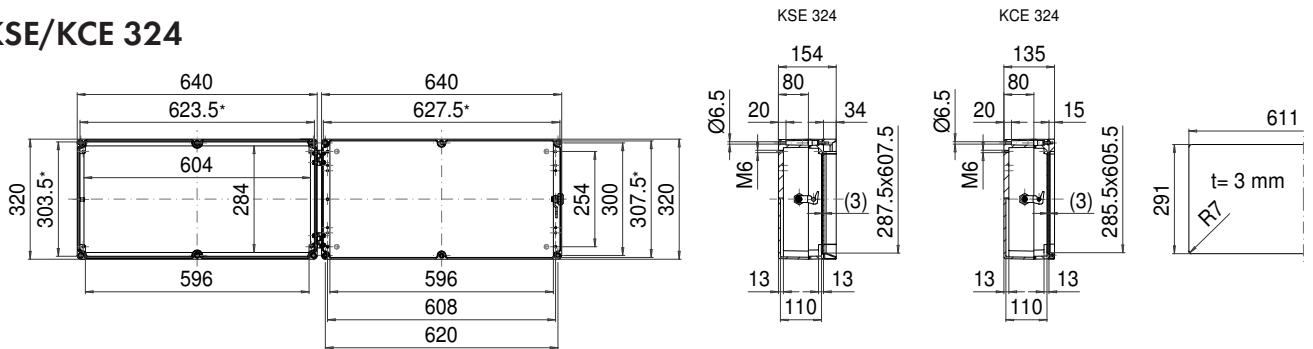

\* Please note: Mould slope for casting ejection, dimensions in the amount of the bottom!