

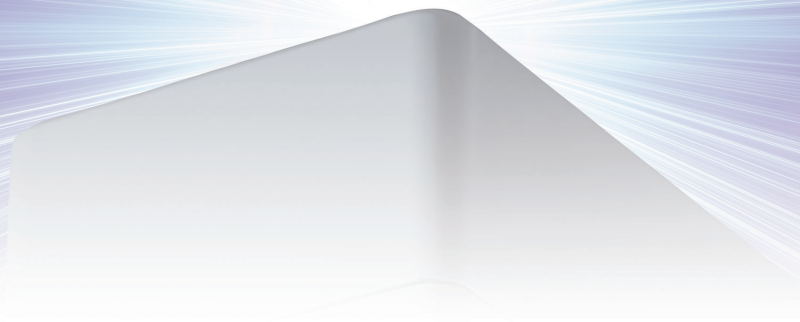

Our *passion* is enclosures.

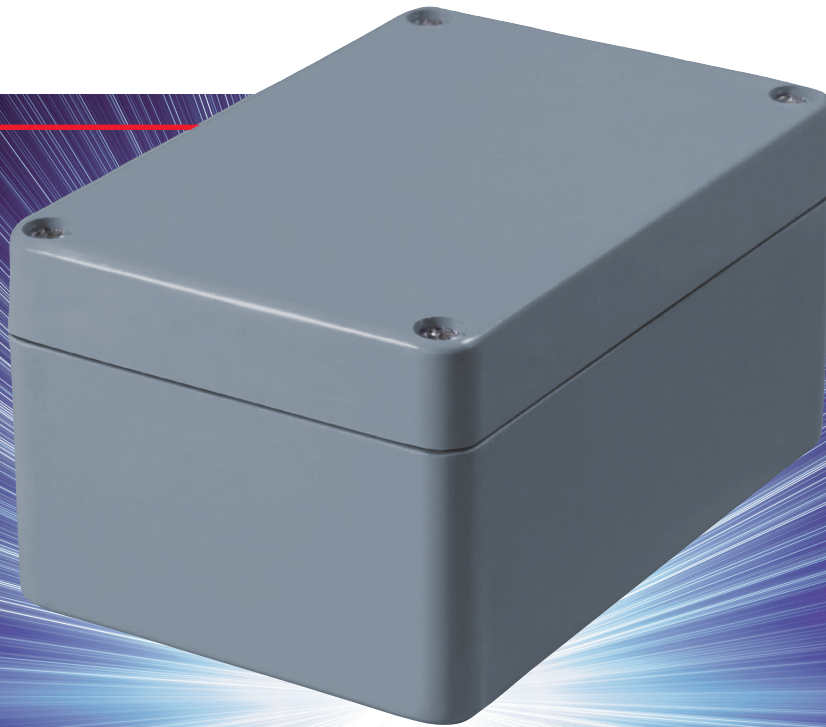

polyKOM

Standard enclosures made of glass fibre reinforced polyester

Technical data

polyKOM



Compatible with conventional brands



Hinge



External mounting feet V2A



Hold hinge



Hexagon socket lid screws

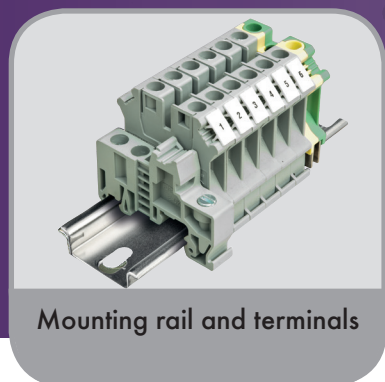

Mounting rail and terminals



Mounting plate

Enclosure: Polyester glass fibre reinforced, halogen-free
1° mould slope for casting ejection, internal measures diminishing
circulatory towards enclosure bottom by 1°.

Components: Mounting webs with M4/M6
threaded bushing in the enclosure bottom.

Fastening: Separate screw channels outside of the
enclosure interior

Flammability: UL 94 V-0, self-extinguishing

Ingress Protection: IP65 / EN 60529

Gasket: Chloroprene (CR) gasket (-30°C to +90°C)

Captive screws: Stainless steel 1.4567 (V2A), captive

Surface: RAL 7000, squirrel grey, surface resistance > 10⁹ Ω

Optionally available:

External mounting feet: Stainless steel 1.4301 (V2A)

Mounting plates: Sheet steel, galvanised

Gasket: Silicone gasket (-50°C to +140°C)

Surface: RAL 9005, deep black, surface resistance < 10⁹ Ω

Further options, see delivery overview.

Delivery overview polyKOM

Type	Mat. no.	L	W	H	D	E	g	A	S	HS	IN	M	D	T
PK 081	180.081.000	80	75	55	68	45	230	○	○	○	○	●	●	●
PKH 081	182.081.000	80	75	75	68	45	300	○	○	○	○	●	●	●
PK 082	180.082.000	110	75	55	98	45	295	○	○	○	○	●	●	●
PK 083	180.083.000	160	75	55	148	45	405	○	○	○	○	●	●	●
PK 084	180.084.000	190	75	55	178	45	450	○	○	○	○	●	●	●
PK 121	180.121.000	122	120	90	106	82	750	●	●	●	●	●	●	●
PK 123	180.123.000	220	120	90	204	82	1.060	●	●	●	●	●	●	●
PK 161	180.161.000	160	160	90	140	110	1.130	●	●	●	●	●	●	●
PK 162	180.162.000	260	160	90	240	110	1.710	●	●	●	●	●	●	●
PK 163	180.163.000	360	160	90	340	110	2.150	●	●	●	●	●	●	●
PK 164	180.164.000	560	160	90	540	110	3.185	●	●	●	●	●	●	●
PK 251	180.251.000	255	250	120	235	200	2.650	●	●	●	●	●	●	●
PK 252	180.252.000	400	250	120	380	200	3.650	●	●	●	●	●	●	●
PK 254	180.254.000	600	250	120	580	200	5.235	●	●	●	●	●	●	●
PK 411	180.411.000	400	405	120	380	355	5.580	●	●	●	●	●	●	●

□ Standard ● Available ○ Not available

Approvals:



Extended approvals:

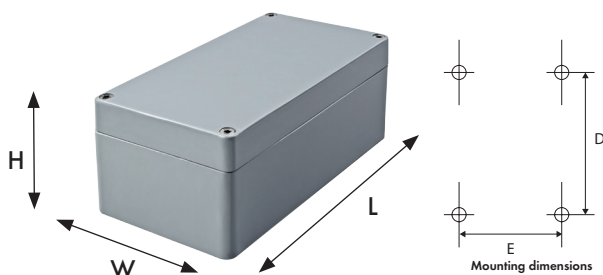

ROLEC Attachment and mounting dimensions

polyKOM

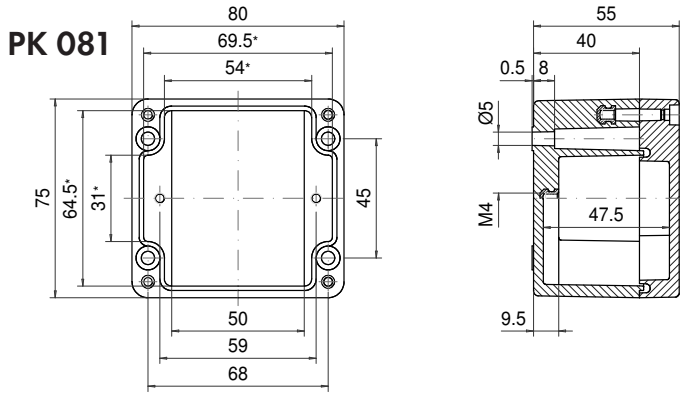

* Please note: Mould slope for casting ejection, dimensions in the amount of the bottom!

Maximum number of cable glands per enclosure side			
C	A		A/B C/D
	B	D	
M 16	PG 7	5	2
	PG 9	3	1
M 20	PG 11	2	1
	PG 13,5	2	1
M 25	PG 16	2	1
	PG 21	1	
M 32	PG 29		
M 40	PG 36		
M 50	PG 42		
M 63	PG 48		

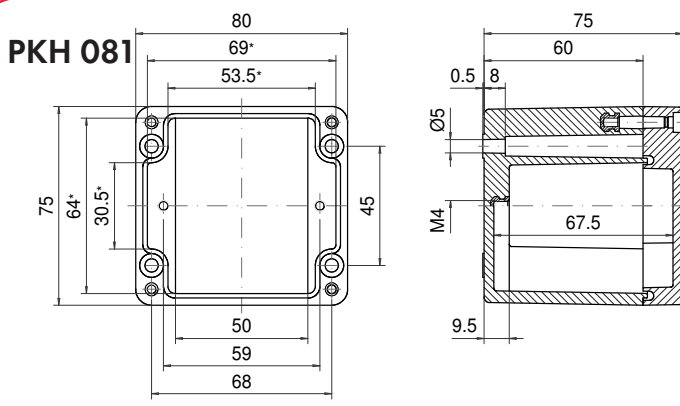

* Please note: Mould slope for casting ejection, dimensions in the amount of the bottom!

Maximum number of cable glands per enclosure side			
C	A		A/B C/D
	B	D	
M 16	PG 7	6	4
	PG 9	6	2
M 20	PG 11	4	2
	PG 13,5	4	2
M 25	PG 16	3	1
	PG 21	1	1
M 32	PG 29	1	
M 40	PG 36		
M 50	PG 42		
M 63	PG 48		

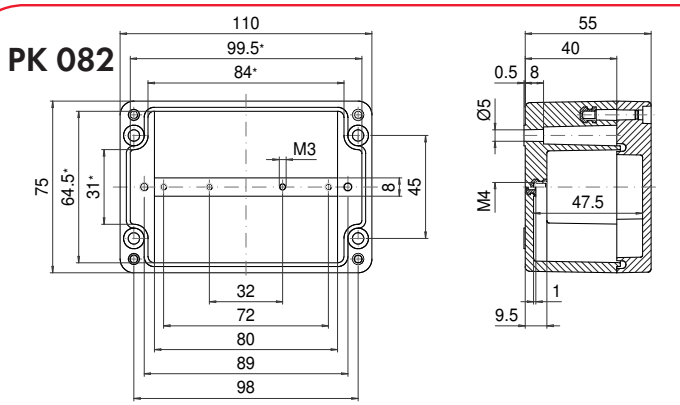

* Please note: Mould slope for casting ejection, dimensions in the amount of the bottom!

Maximum number of cable glands per enclosure side			
C	A		A/B C/D
	B	D	
M 16	PG 7	8	8
	PG 9	5	1
M 20	PG 11	3	1
	PG 13,5	3	1
M 25	PG 16	3	1
	PG 21	2	
M 32	PG 29	2	
M 40	PG 36		
M 50	PG 42		
M 63	PG 48		

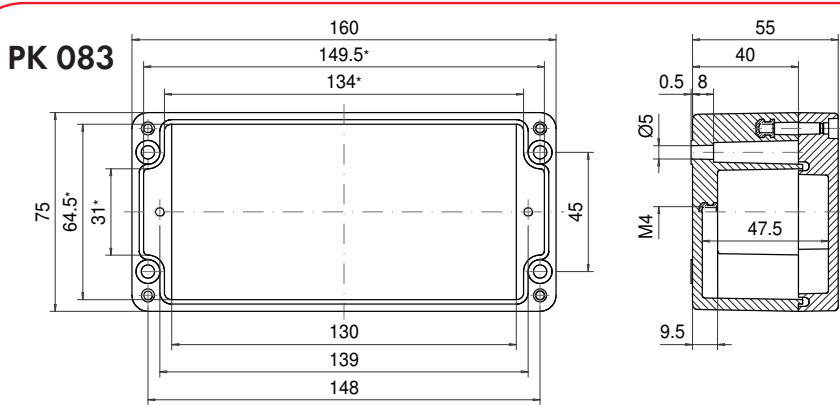

* Please note: Mould slope for casting ejection, dimensions in the amount of the bottom!

Maximum number of cable glands per enclosure side			
C	A		A/B C/D
	B	D	
M 16	PG 7	13	2
	PG 9	8	1
M 20	PG 11	6	1
	PG 13,5	5	1
M 25	PG 16	4	1
	PG 21	3	
M 32	PG 29		
M 40	PG 36		
M 50	PG 42		
M 63	PG 48		

PK 084

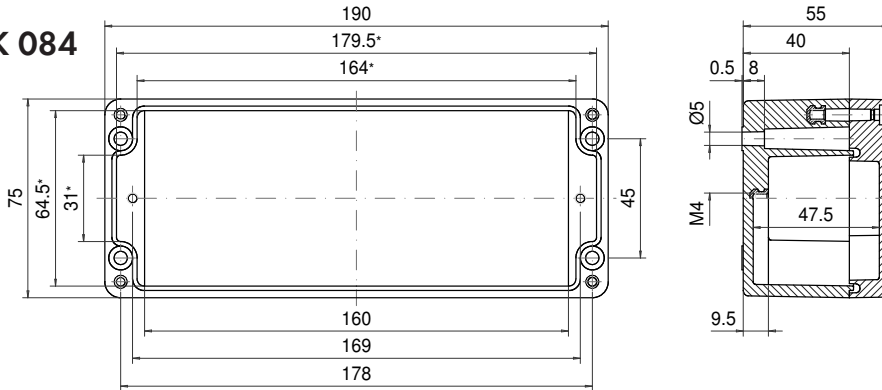

* Please note: Mould slope for casting ejection, dimensions in the amount of the bottom!

Maximum number of cable glands per enclosure side

A		A/B/C/D	
C	D	A	B/C/D
	B	PG 7	16 2
M 16		PG 9	10 1
		PG 11	7 1
M 20		PG 13,5	6 1
		PG 16	5 1
M 25		PG 21	4
M 32		PG 29	
M 40		PG 36	
M 50		PG 42	
M 63		PG 48	

PK 121

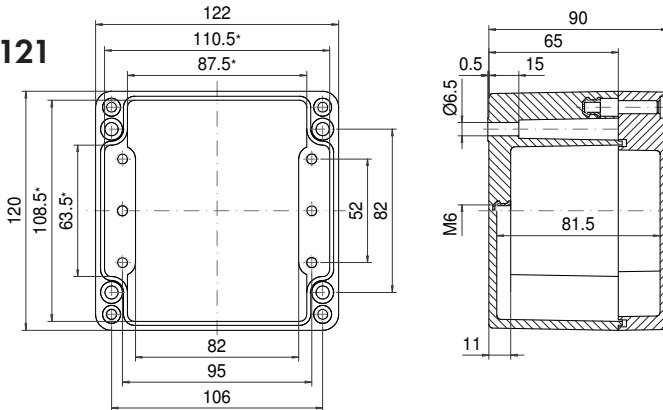

* Please note: Mould slope for casting ejection, dimensions in the amount of the bottom!

Maximum number of cable glands per enclosure side

A		A/B/C/D	
C	D	A	B/C/D
	B	PG 7	12 8
M 16		PG 9	8 6
		PG 11	8 4
M 20		PG 13,5	6 4
		PG 16	6 3
M 25		PG 21	2 2
M 32		PG 29	2 1
M 40		PG 36	1
M 50		PG 42	
M 63		PG 48	

PK 123

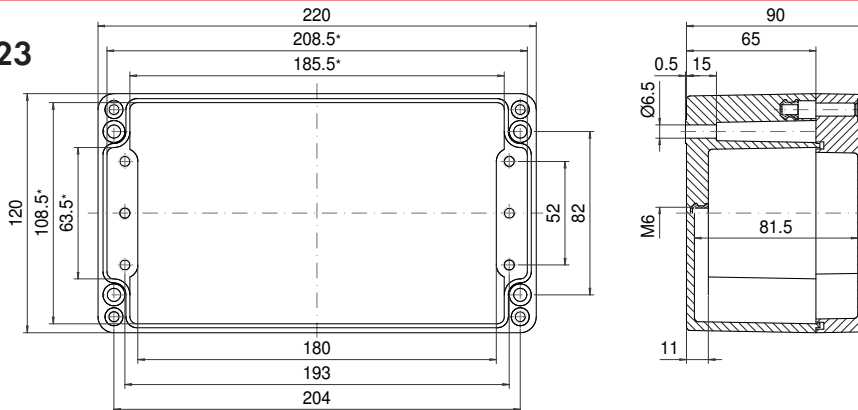

* Please note: Mould slope for casting ejection, dimensions in the amount of the bottom!

Maximum number of cable glands per enclosure side

A		A/B/C/D	
C	D	A	B/C/D
	B	PG 7	27 8
M 16		PG 9	20 6
		PG 11	16 4
M 20		PG 13,5	14 4
		PG 16	12 3
M 25		PG 21	5 2
M 32		PG 29	3 1
M 40		PG 36	3 1
M 50		PG 42	
M 63		PG 48	

PK 161

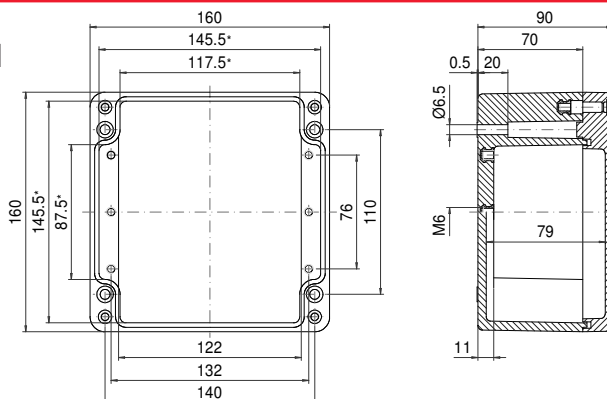

* Please note: Mould slope for casting ejection, dimensions in the amount of the bottom!

Maximum number of cable glands per enclosure side

A		A/B/C/D	
C	D	A	B/C/D
	B	PG 7	18 12
M 16		PG 9	15 8
		PG 11	10 8
M 20		PG 13,5	10 6
		PG 16	8 6
M 25		PG 21	4 2
M 32		PG 29	2 2
M 40		PG 36	2 1
M 50		PG 42	1
M 63		PG 48	

ROLEC Attachment and mounting dimensions

polyKOM

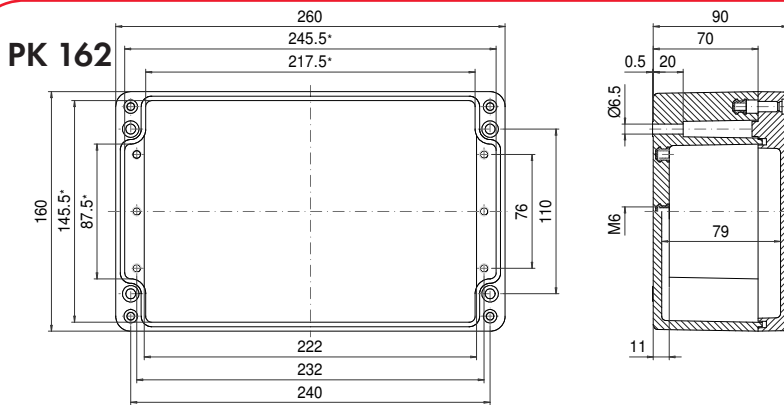

Maximum number of cable glands per enclosure side			
A	B	C/D	A/B/C/D
PG 7	36	12	
M 16	PG 9	30	8
	PG 11	18	8
M 20	PG 13,5	18	6
	PG 16	14	6
M 25	PG 21	7	2
M 32	PG 29	4	1
M 40	PG 36	3	1
M 50	PG 42	3	
M 63	PG 48		

* Please note: Mould slope for casting ejection, dimensions in the amount of the bottom!

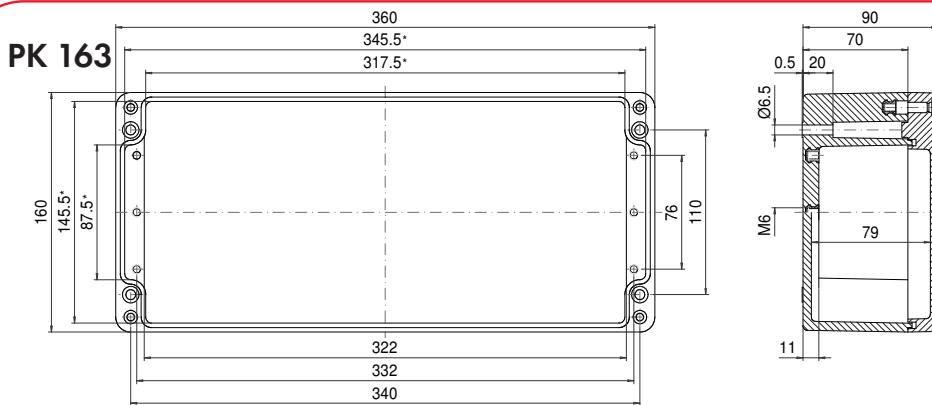

Maximum number of cable glands per enclosure side			
A	B	C/D	A/B/C/D
PG 7	51	12	
M 16	PG 9	42	8
	PG 11	28	8
M 20	PG 13,5	26	6
	PG 16	20	6
M 25	PG 21	11	2
M 32	PG 29	6	2
M 40	PG 36	5	1
M 50	PG 42	4	
M 63	PG 48		

* Please note: Mould slope for casting ejection, dimensions in the amount of the bottom!

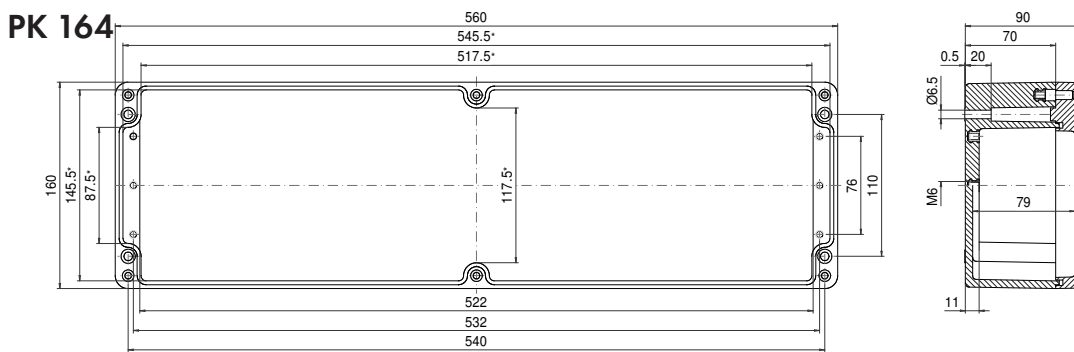

Maximum number of cable glands per enclosure side			
A	B	C/D	A/B/C/D
PG 7	89	12	
M 16	PG 9	66	8
	PG 11	44	8
M 20	PG 13,5	40	6
	PG 16	32	6
M 25	PG 21	16	2
M 32	PG 29	10	2
M 40	PG 36	8	1
M 50	PG 42	6	
M 63	PG 48		

* Please note: Mould slope for casting ejection, dimensions in the amount of the bottom!

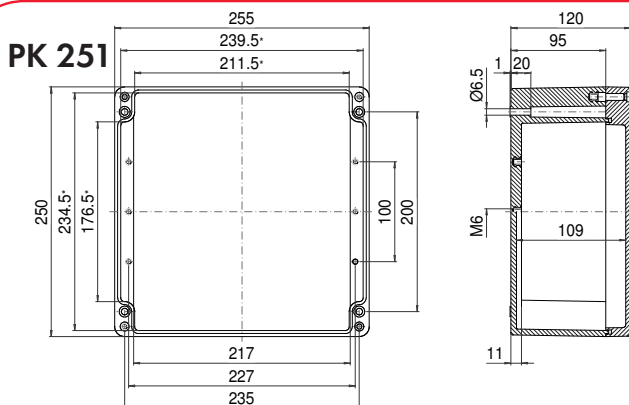

Maximum number of cable glands per enclosure side			
A	B	C/D	A/B/C/D
PG 7	48	40	
M 16	PG 9	40	27
	PG 11	27	21
M 20	PG 13,5	24	21
	PG 16	14	12
M 25	PG 21	10	8
M 32	PG 29	7	5
M 40	PG 36	4	3
M 50	PG 42	3	2
M 63	PG 48	3	2

* Please note: Mould slope for casting ejection, dimensions in the amount of the bottom!

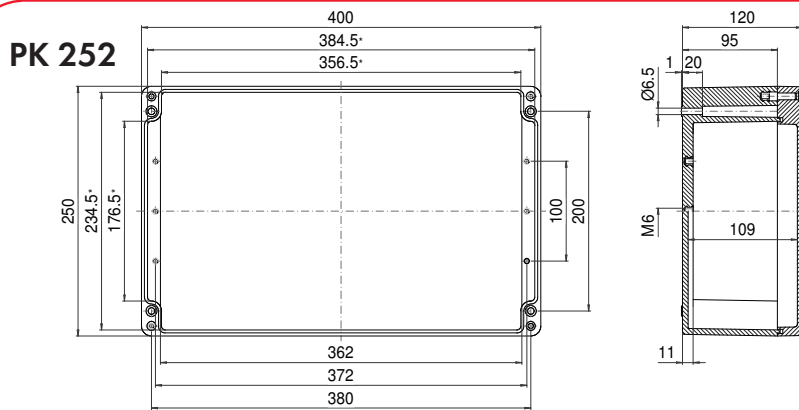

* Please note: Mould slope for casting ejection, dimensions in the amount of the bottom!

Maximum number of cable glands per enclosure side

C	A		A/B C/D	
	B	D	A/B	C/D
			PG 7	84 36
M 16			PG 9	64 27
			PG 11	48 21
M 20			PG 13,5	42 18
			PG 16	26 12
M 25			PG 21	18 8
M 32			PG 29	12 5
M 40			PG 36	6 3
M 50			PG 42	5 2
M 63			PG 48	5 2

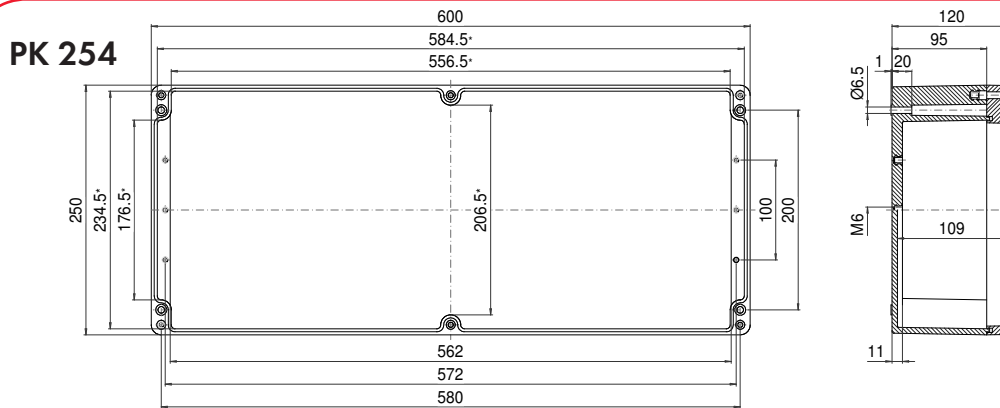

* Please note: Mould slope for casting ejection, dimensions in the amount of the bottom!

Maximum number of cable glands per enclosure side

C	A		A/B C/D	
	B	D	A/B	C/D
			PG 7	120 36
M 16			PG 9	96 27
			PG 11	72 21
M 20			PG 13,5	66 18
			PG 16	36 12
M 25			PG 21	28 8
M 32			PG 29	18 5
M 40			PG 36	10 3
M 50			PG 42	8 2
M 63			PG 48	6 2

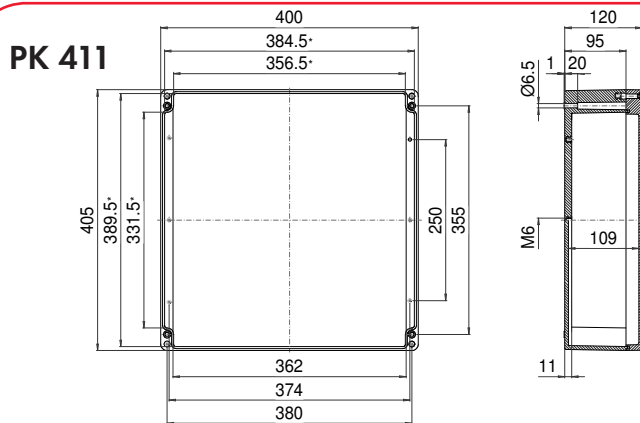

* Please note: Mould slope for casting ejection, dimensions in the amount of the bottom!

Maximum number of cable glands per enclosure side

C	A		A/B C/D	
	B	D	A/B	C/D
			PG 7	84 72
M 16			PG 9	64 51
			PG 11	48 42
M 20			PG 13,5	42 36
			PG 16	26 24
M 25			PG 21	18 16
M 32			PG 29	12 9
M 40			PG 36	6 6
M 50			PG 42	5 5
M 63			PG 48	5 4

